

Commercial System Design Guidelines

- 1. Introduction..... 1
- 2. Determine the number of Modules/Inverters required. 1
- 3. Determining the number of Microinverters per branch circuit 1
- 4. Determine the number of Branch Circuits required 2
- 5. Determine the number of Communications Domains required 3
- 6. Best Practices 6

1. Introduction

When designing a large grid tied PV system using the Enphase Micro-Inverter system, there are a few recommendations to minimize costs and maximize performance. AC branch circuits can be combined using readily available components, saving material and labor costs, as well as reducing the energy lost to voltage drop. The circuits can also be arranged to ensure high quality transmission within the powerline communications domains. This document will outline the design flow and make best practice recommendations.

2. Determine the number of Modules/Microinverters required.

The desired system size for this example is 250 kW STC
 The chosen PV module is rated at 220 watts STC
 The number of modules required would be:

$249,480 \text{ W} \div 220 \text{ W/Module} = 1134 \text{ modules}$
--

(1134 modules is 2 less than 250 KW but works well with max comm. domain size)

The nominal AC output rating for this system would be 215.5 kW AC

The Enphase Microinverter used in this application note is the M190-72-208-S0x. The M190-72-208-S0x Microinverter manages a single PV module and is designed for 208 Vac 3 phase 4 wire connection. For this example the required number of inverters would be equal to the number of PV modules:

$1134 \text{ modules} = 1134 \text{ Microinverters}$
--

3. Determining the number of Microinverters per branch circuit

The National Electric Code defines a branch circuit as the circuit conductors between the final overcurrent device protecting the circuit and the devices. The Microinverters connect end to end to create a chain. The beginning of this chain is wired to a circuit breaker in the main distribution panel or a local load center. This collection of Microinverters and wiring make up the Microinverter branch circuit. The maximum size of the circuit breaker protecting each Microinverter branch circuits is 15 amps.

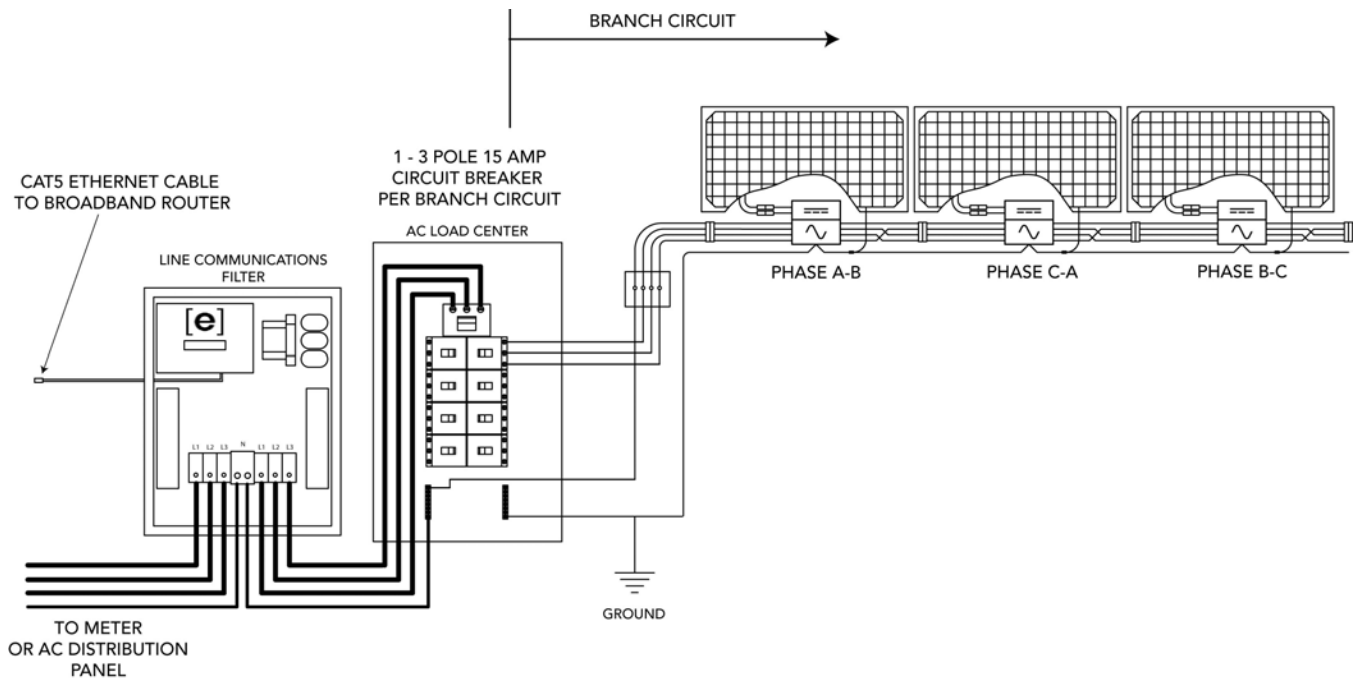

Since the power output of a photo-voltaic inverter is considered to be continuous, the conductors and overcurrent protection devices must be sized to carry not less than 125% of the inverter rated output.

$15 \text{ amps} \div 1.25 = 12 \text{ amps}$ nominal current maximum per 15 amp circuit breaker

The maximum total Microinverter power allowable on a 15 amp circuit breaker at 208 Vac would be:

$$12 \text{ amps nominal} \times \sqrt{3} \times 208 \text{ Vac} = 4318 \text{ watts}$$

The rated power output of the M190-72-208-S01 is 190 watts ac.

$$4318 \text{ watts} \div 190 \text{ watts} = 22.7 \text{ Microinverters per 15 amp circuit breaker}$$

Conclusion:

For a 208 Vac 3 phase circuit the maximum number of M190 Microinverters allowed on a single branch circuits is 22, however to balance the phase currents and reduce voltage drop we recommend 21 per branch circuit.

4. Determine the number of Branch Circuits required

We determined in step 2 that 1134 modules/Microinverters are required. We determined in step 3 that the maximum number of Microinverters per branch circuit is 21.

1134 Microinverters ÷ 21 per branch = 54 branch circuits required

5. Determine the number of Communications Domains required



Line Communications Filter

The Enphase Envoy gateway is the data logger / internet gateway for the Microinverters in the Enphase Microinverter system. The Microinverters communicate performance and production data over powerline to the Envoy. We refer to a grouping of one Envoy and the Microinverters associated with it as a single communications domain. For systems larger than 189 Microinverters or 34 kW, more than one Envoy is required. When multiple Envoy gateways are required, a Line Communications Filter is also required, to prevent communications data from one communications domain from cross-talking to another.

The Line communications filter has a maximum current rating of 100 amps. The maximum overcurrent protection device rating is 125 amps. This rating works well with a 125 amp, 24 space main lug load center containing nine 3-pole 15 amp breakers. Nine branch circuits fully loaded with 21 Microinverters each, equals a total of 189 Microinverters. The output of the load center would pass through the Line Communications Filter enclosure on their way to the main power distribution panel.

The calculation for load center loading would be:

9 branch circuits x 21 Microinverters each = 189 Microinverters
189 Microinverters x 190 watts each = 35,910 watts
 $35,910 \text{ watts} \div 208 \text{ volts} \div \sqrt{3} = 99.79 \text{ amps}$
 $99.79 \text{ amps} \times 1.25 = 124.73 \text{ amps}$ or a 125 amp load center

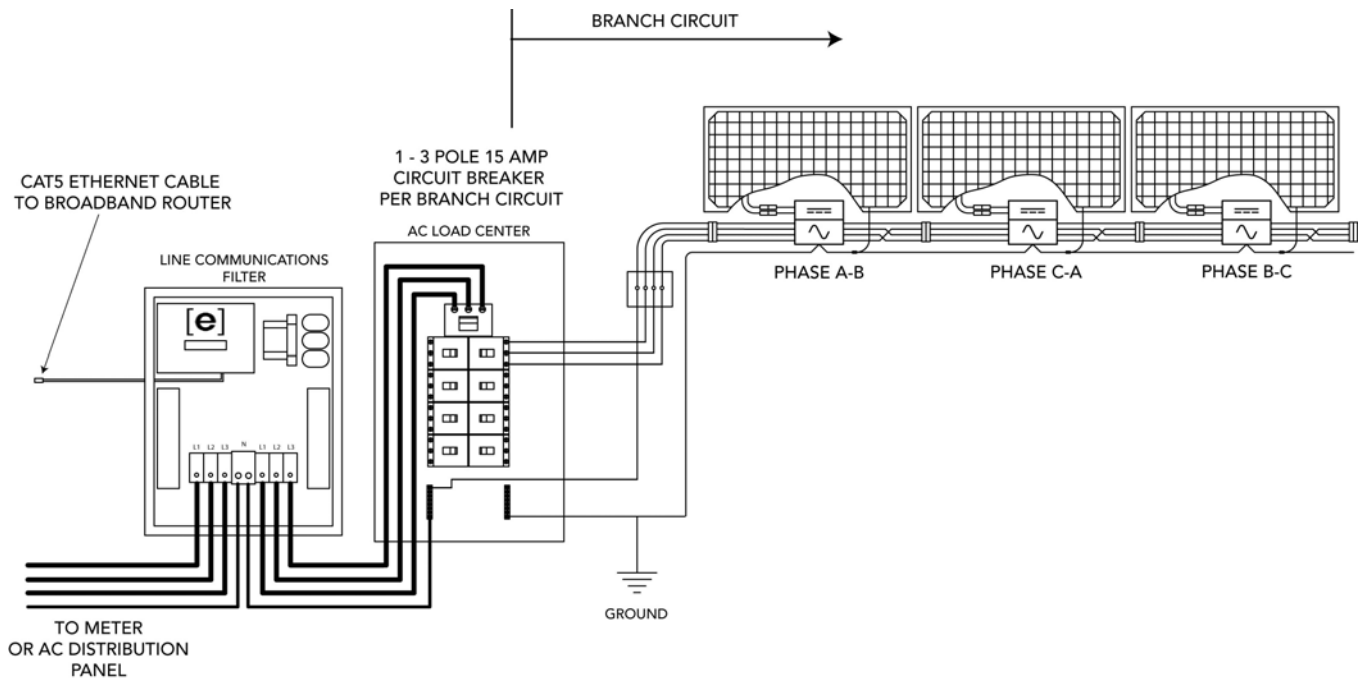

The line communication filter contains a filter network that prevents the powerline communications from exiting the communications domain. The line communications filter also contains an Envoy gateway that is connected to the Microinverter side of the filter network.

Conclusion:

$54 \text{ branch circuits required} \div 9 \text{ branch circuits per load center} = 6$
--

6 Communications domains are required

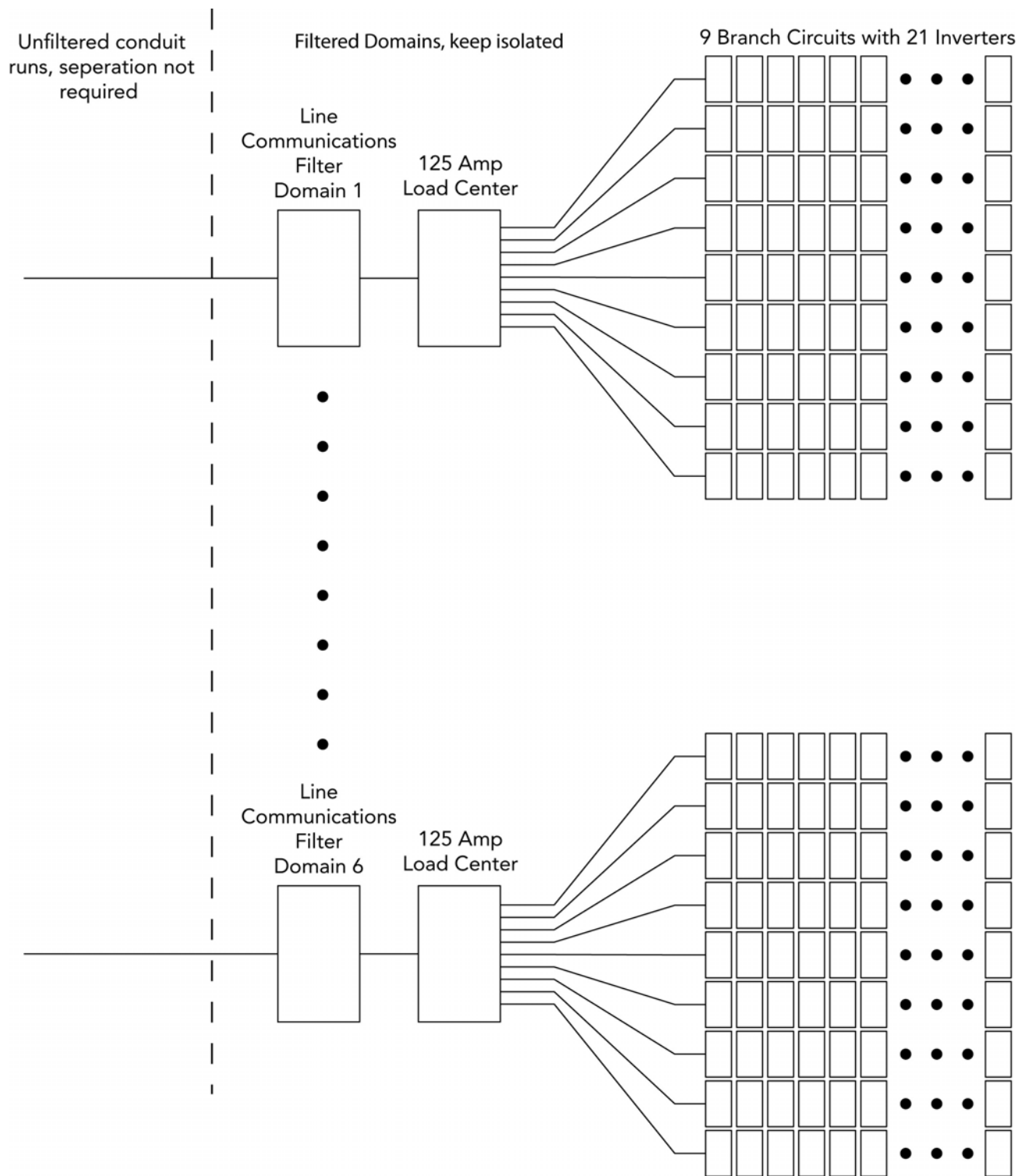

6. Best Practices

Locating the Load Centers, Line Communications Filters

By locating the load centers close to the array, the branch circuit lengths are kept to a minimum. Consolidating the branch circuits into a single larger ampacity circuit will reduce material costs. Using a distance of 200 feet for example, installing a single 1 ½" conduit with #1 AWG instead of installing 8 ¾" conduits with #10 AWG would save 44% on material cost.

Locating the load center close to the array allows the Line Communications Filter to be located close to the array as well. If conduit runs from different communications domains are closely paralleled prior to the LCF, it is possible that the domains will cross talk. By containing the powerline communications close to the array, the possibility of cross talk will be greatly reduced.

Metal conduit is preferred for the shielding against induced signals that it provides. If PVC conduits are used Enphase recommends at least 12" of separation if the conduits are from different communications domains.

Size Conductors for Voltage Drop

Installing the minimum allowable conductor size per NEC guidelines will be adequate for current flow requirements but is not always adequate to prevent excessive voltage drop in the branch and feeder circuits. The resistance in long circuit lengths can cause the circuit voltage to rise outside of IEEE allowable levels, causing the inverters to drop off line. The power consumed by this line loss is energy that is not delivered to the utility. Enphase recommends using the circuit calculation application notes located in the support section on our website, enphaseenergy.com, to help determine the wire gauge based on the number of inverters per branch. The application notes are separated by system voltage. For systems with long individual branch circuit runs, the voltage drop inside the Microinverter cabling can be greatly reduced by feeding the branch circuits in the middle of the branch. This requires an additional AC Interconnect cable per branch circuit. The calculations for center feeding the branch circuits are also described in the circuit calculation application notes.

Isolate Neutrals

It is a requirement that the circuit feeding each Line Communications Filter as well as the individual branch circuits would contain a conductor for L1, L2, L3, and neutral. It is important that the conductors on the inverter side of the Line Communications Filter do not come in contact with conductors from other communications domains. Even though the neutral conductors meet at the point of interconnect to the utility, it is important that they are separated once they are on the inverter side of the Line Communications Filter.