

Installation and Operation Manual

Environ™ Smart Thermostat





Contact Information

Enphase Energy Inc.
201 1st Street
Petaluma, CA 94952
Phone: 707-763-4784 TOLL FREE: 877-797-4743
Fax: 707-763-0784

www.enphaseenergy.com
info@enphaseenergy.com

FCC Compliance

This equipment has been tested and found to comply with the limits for a Class B digital device, pursuant to part 15 of the FCC Rules. These limits are designed to provide reasonable protection against harmful interference in a residential installation. This equipment generates, uses and can radiate radio frequency energy and, if not installed and used in accordance with the instructions, may cause harmful interference to radio communications. However, there is no guarantee that interference will not occur in a particular installation. If this equipment does cause harmful interference to radio or television reception, which can be determined by turning the equipment off and on, the user is encouraged to try to correct the interference by one or more of the following measures:

- Reorient or relocate the receiving antenna.
- Increase the separation between the equipment and the receiver.
- Connect the equipment into an outlet on a circuit different from that to which the receiver is connected.
- Consult the dealer or an experienced radio/TV technician for help.

Changes or modifications not expressly approved by the party responsible for compliance may void the user's authority to operate the equipment.

Table of Contents

1	Important Safety Information	5
	Read this First	5
	Safety Instructions	5
2	The Enphase Environ Smart Thermostat	6
	Other Elements in the Enphase System	6
	How the Environ Smart Thermostat Works with the Enphase System	7
3	Environ Installation	8
	Location	8
	Remove the Old Unit	9
	What wires do you have?	10
	Prepare Wires	10
	Connect Wires	11
	Mount the Environ to Wall	12
	HVAC Set-up on Screen Menu	12
	Set-up for Normal Heating Systems (not heat pump)	12
	Set-up for Normal A/C Cooling Systems:	13
	Set-Up for Heat Pump Systems:	13
	Check HVAC System	14
4	Configuring the Environ	16
5	Environ Interface to Envoy	18
	Install the Envoy	18
	Install Environ	18
	Connect Envoy to ZigBee Network	18
	Verify that the Envoy and Environs have Mated	19
	Troubleshooting	19
6	Operating the Environ through Enlighten	20
	Enlighten Monitoring System	20
	Environ Summary on My System page	20
	Configuration and Programs	22
	Environ Configuration	23
	Smartphone Access	25
7	Environ Local Interface	26
	Control Screens	26
	Home Screen	27
	Manual Screen	27
	Menu Screen	28
	Menu Functions	29
	Save Energy Button	37
	Fan control	37
	Power Button and Mode selection	37
	HVAC Status	38
	Reset Button	38
	Zoned Systems Wire Reference Chart	40
8	Appendix	41
	Limited Warranty	41

1 Important Safety Information

Read this First

This manual contains important instructions to follow during installation and maintenance of the Enphase Environ Smart Thermostat.

To reduce the risk of electrical shock, and to ensure the safe installation and operation of the Environ, the following safety symbols appear throughout this document to indicate hazardous conditions and important safety instructions.



WARNING: This indicates a situation where failure to follow instructions may cause a serious hardware failure. Use extreme caution when performing this task.



NOTE: This indicates information particularly important for optimal system operation. Follow these instructions closely.

Safety Instructions

Perform all electrical installations in accordance with all local electrical codes and the National Electrical Code (NEC), ANSI/NFPA 70.

Be aware that only qualified personnel shall install or replace the Enphase Environ Smart Thermostat.

Do not attempt to repair the Enphase Environ. It contains no user-serviceable parts. If the Enphase Environ fails, please return the unit to your distributor for maintenance. Tampering with or opening the Environ will void the warranty.

Before installing or using the Enphase Environ, please read all instructions and cautionary markings in the technical description and on the Enphase Environ



NOTE: For Enphase Environ Warranty Terms and Conditions see the Appendix on page 41 of this manual.

2 The Enphase Environ Smart Thermostat

The Enphase Environ™ is the world's first solar-integrated, web-enabled, smart thermostat. Using plug-and-play wireless technology, the Environ connects to the Envoy Communications Gateway, and is integrated with the Enlighten™ website. This allows you to monitor and control your heating and cooling at the wall, on the web or from your smart phone.

The Environ Smart Thermostat is compatible with all popular residential HVAC systems:

- 24VAC single, two, three stage conventional heating systems (gas/oil/electric)
- heat pumps (single and two stage compression)
- single or two stage auxiliary heat (electric or fossil)
- zoned forced air and zoned hot water (2 or 3 wire) (Enphase Energy recommends professional HVAC installation for zoned forced-air systems due to additional equipment for baffles, etc.)
- millivolt systems (with 24VAC adapter)
- one or two stage cooling
- hybrid systems.

The Enphase Environ™ will control temperature to an accuracy of $\pm 1^\circ$ F and is designed to work with ambient temperatures from 35° F to 95° F

Heating or cooling temperatures can easily be set on the large touchscreen with the +/- buttons. A minimum 4 minute off time protects heating and cooling compressors from damage. This thermostat uses a new technique called sequential staging for more comfort with faster reaction to requested temperature changes.

This thermostat must be run on the HVAC system's 24VAC (C wire) or external 24VAC transformer connected to the C and RH terminals. The 24VAC C wire is located on the other side of the 24VAC heating transformer, and can be found where the other thermostat wires connect at the wall or at the furnace.

Other Elements in the Enphase System

The **Enphase Enlighten** web-based monitoring and analysis system analyzes the per-module data collected by each microinverter. Enlighten automatically detects any shortfall in energy production, identifies possible causes, and suggests solutions to correct the problem. The Enphase Enlighten website is constantly monitoring every module on every installation.

The Enphase Envoy communications gateway and the Enlighten Energy Monitoring capability have been expanded to support additional smart energy

devices and services such as the Environ Smart Thermostat. This capability enables Enphase Systems to not only generate clean energy, but also to monitor and control energy usage.

Through Enlighten, you can manage your Environ Smart Thermostat from anywhere through the Enphase Enlighten web-based portal. Enlighten enables you to view and edit your programs and settings. It provides:

- ease of use of setting configurations and setting up 7-day programs through a large web browser window rather than on the wall-mounted unit.
- the ability to access these settings online from any browser, as well as smartphones.
- visibility to solar production information and HVAC controls side-by-side on the same portal.

The **Enphase Envoy** is an integral component of the Enphase Energy Microinverter system. It operates between the Enphase Environ, microinverters, and the Enphase Enlighten web-based monitoring and analysis system. The Envoy functions as a gateway and monitors the microinverters that are connected to the photovoltaic modules.

The **Enphase Microinverter** is a fully integrated device that converts the DC output of a single solar module into grid-compliant AC power. In addition to performing the DC to AC conversion, it maximizes the modules' energy production by using a sophisticated Maximum Power Point Tracking (MPPT) algorithm.

How the Environ Smart Thermostat Works with the Enphase System

The Environ programmable communicating thermostat interfaces to the Enphase Envoy communications gateway using a ZigBee wireless interface. This interface is designed to be plug and play.

Once mated, the Environ can be reached and programmed through the Enlighten website from virtually any location.

3 Environ Installation

Your thermostat is a precise instrument; please handle it with care.

Turn off electricity to the HVAC system before installing or servicing the thermostat or any part of the system. Power can be disconnected at the circuit breaker or at the HVAC system.



Do not turn electricity back on until work is completed.

Do not short (jumper) across electric terminals at the control on the furnace or air conditioner to test the system. This may damage the thermostat.

All wiring must conform to local codes and ordinances.

This thermostat is designed for use with 24VAC and millivolt systems with a separate 24VAC power adapter.



The thermostat relay load should be limited to 1.0 amp. Higher amperage may cause damage to the thermostat.



You will need a small Phillips screwdriver and a drill with 3/16-in. (4.8mm) bit for wall mounts.

Location

Replacement installations: mount the Environ in place of the thermostat. You must have a C wire or other 24VAC power available at the Environ location. A new location will require moving your wiring.

For new installations and for re-locating the Environ, follow these guidelines:

- Locate the thermostat on an inside wall, about 5 ft. (1.5m) above the floor, and in a room that is frequently used.
- Do not install it where there are unusual heating conditions, such as: in direct sunlight; near a lamp, radio, television, radiator register, fireplace; near hot water pipes in a wall; or near a stove on the other side of a wall.

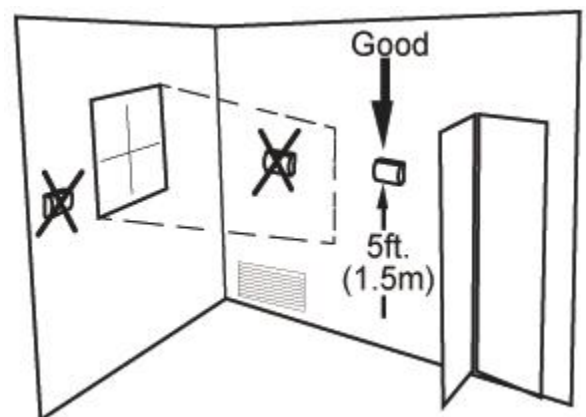

- Do not locate in unusual cooling conditions, such as: on a wall separating an unheated room; or in a draft from a stairwell, door, or window.
- Do not locate in a damp area. This can lead to corrosion that will shorten thermostat life.
- Do not locate where air circulation is poor, such as: in a corner, an alcove; behind an open door.
- Do not install the Environ until all construction and painting has been completed.



Note: The thermostat does not require leveling.

Remove the Old Unit



Read the instructions carefully before removing any wiring from the existing thermostat. Wires must be labeled before they are removed. THERE IS NO STANDARD COLOR CODE. When removing wires from their terminals, ignore the color of the wires and LABEL THEM by the terminal where they were screwed.

Switch OFF electricity to the furnace and air conditioner, then follow these steps.

1. Remove the cover from old thermostat. Most are snap-on types and simply pull off. Some have locking screws on the side or front. These must be loosened. DO NOT remove wires. Note the letters printed near the terminals. Attach labels (enclosed) to each wire for identification.
2. Label the wires one at a time. You must label all the wires before you proceed. With all wires labeled, remove them from the old unit.
3. Make sure the wires do not fall back inside the wall. You can wind them around a pencil to keep them from falling.
4. Loosen all screws on the old thermostat and remove it from the wall.

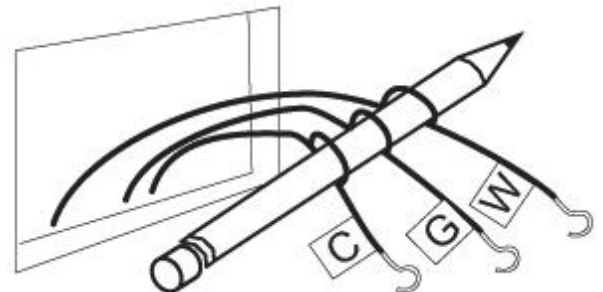

What wires do you have?

Make sure your wires are labeled. This may require you to find the *other end* connection for each wire on your heating or air conditioning equipment and read the label there. Refer to the Wire Reference on page 39 for better understanding of wire labels from different HVAC system makers.



IMPORTANT: C wire or 24VAC power is required for the Environ to operate. If you do not have a C wire, you can run a new wire from the HVAC to the Environ or provide 24VAC power to operate the Environ using a standard 24VAC wall transformer.

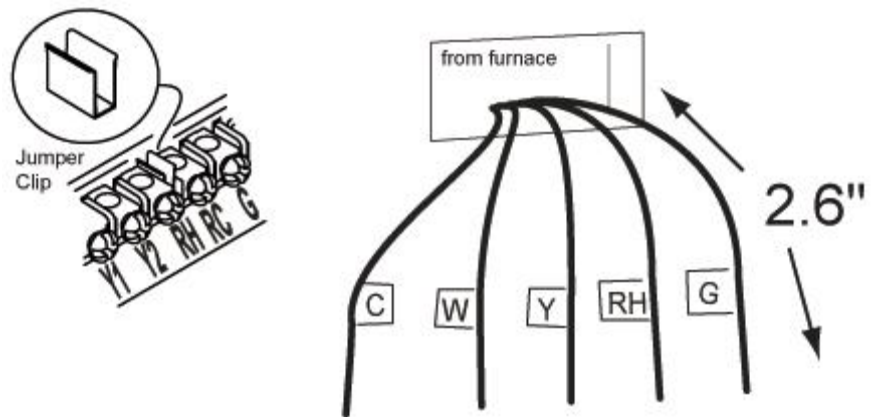

IMPORTANT: If you have both RH and RC, remove the metal jumper-clip between these 2 terminals.



IMPORTANT: If you have both O and B, refer to page 39 for wiring information.

Prepare Wires

Please follow these guidelines for safe and secure wire connections:

- You will need at least 2.6" (66 mm) of wire for each of your connections to the Environ.
- If you do not have enough wire, splice additional wire to allow enough slack.
- Fan out wires below the hole as shown.
- Remove insulation 1/8" (3 mm) from the tip of each wire.
- Take care not to damage the labels for each wire in handling.



Do not allow wires to touch each other or parts on the thermostat.

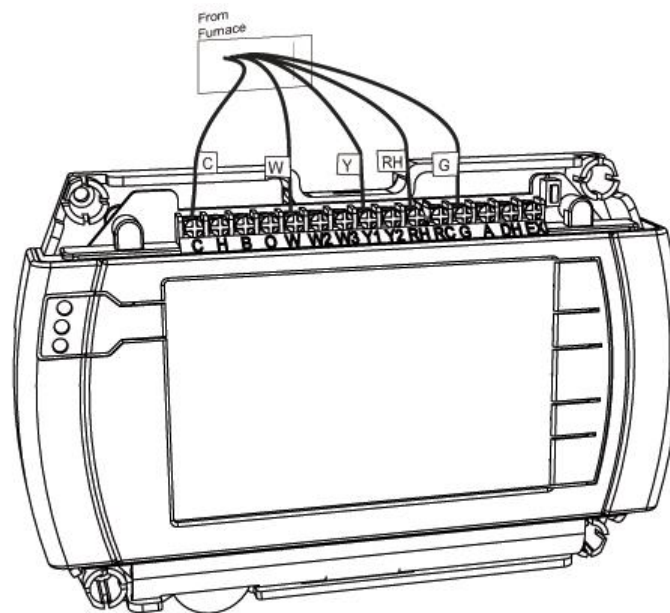

1. Fan wires out as illustrated with the Envirotherm below the wall opening. As in the example, fan out the wires so that the C wire is above the C terminal, the W above the W, and so forth. This allows the Envirotherm to fit snugly to the wall.
2. Wires will position behind the Envirotherm and up over the terminal area.
3. Do not bunch wires behind the Envirotherm. Feed any slack back into the wall opening.

Connect Wires

1. Connect labeled wires only to a terminal with the same letter label.
2. Insert the wire in the terminal well and tighten the screw securely. Do not over-tighten, this will cut the wire.
3. If you are using a 24VAC transformer (such as Radio Shack PN273-1690), connect it to the C and RH terminals (no polarity).

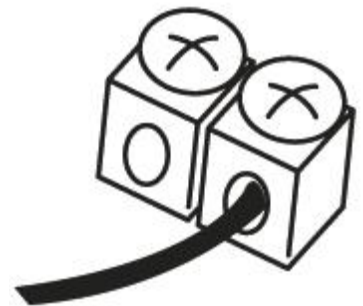

Mount the Environ to Wall

1. Hold the Environ against the wall with the wires coming over the top above terminal block. The Environ will cover the hole in the wall.
2. Position the Environ for best appearance.
3. Attach the Environ to the wall with the screws provided.
4. If you are mounting the Environ to sheet rock, or if you are using the old mounting holes, use the plastic anchors provided.
5. Mark first and drill a 3/16-in.(4.8mm) hole for the insert at each screw location, then mount the Environ.

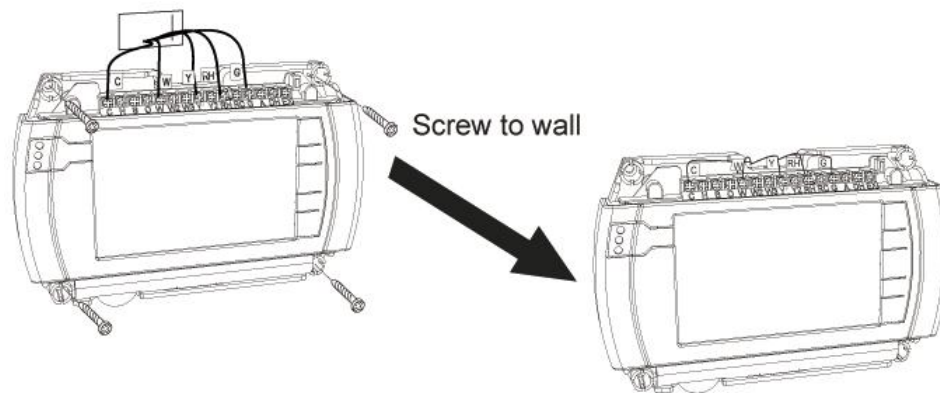

HVAC Set-up on Screen Menu

With all the wires connected (including the C wire), it is time to turn the AC power back on. Do this at the breaker or HVAC system you used to switch it off. The Environ will power-up in the control OFF mode. Your Environ is not configured to operate your HVAC system yet. You must now use the menu driven HVAC SET-UP function.



IMPORTANT: Make sure the Environ is powered up and is in the OFF mode before set-up. To turn your thermostat off, press the **Power** button  in the middle of the control bar to the right of the display and press **OFF**. Heating and cooling systems must be configured separately.

Set-up for Normal Heating Systems (not heat pump)

1. After all the wires are connected, follow the following steps:
2. Remove the pull-tab for the battery located under the bottom cover

3. Press the purple **MENU** button on the control bar and then press HVAC SET-UP.
4. Press to highlight **HEAT** in the upper left corner of the display.
5. Press to highlight **NORMAL**.
6. Your heater can have up to 3 stages. Select the appropriate number of stages by pressing **STAGES** (in brackets) to highlight, and using the +/- buttons to increase or decrease.
7. Press the appropriate FAN CONTROL setting:
 - Select **HVAC** if your heating system controls the fan (appropriate for most gas, oil, propane and similar furnaces).
 - Select **TSTAT** if you want the thermostat to control the fan (for most electric heating systems).
8. Continue to configure COOL or press **HOME** to return to the Home screen.

Set-up for Normal A/C Cooling Systems:

1. Press **MENU** and then press **HVAC SET-UP**.
2. Press and highlight **COOL** in the upper left corner of the display.
3. Select the number of stages of compression for your cooling system (1 or 2) by pressing the number of **STAGES** and using +/- buttons to increase or decrease.
4. Press to select the appropriate **FAN CONTROL** setting **HVAC** or **TSTAT**. **NOTE:** Most cooling systems require that the thermostat **TSTAT** control the fan.
Press **HOME** to return to the Home screen..

Set-Up for Heat Pump Systems:

1. Press **MENU** and then press **HVAC SET-UP**.
2. Press **HEAT** in the upper left corner of the display.
3. Press **HEAT PUMP**.

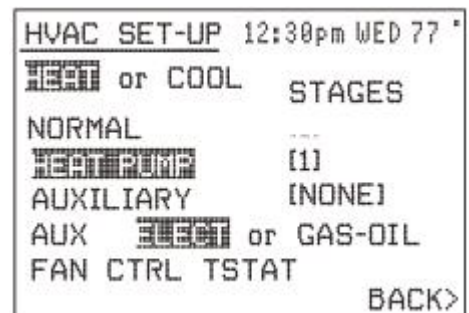

- Select the number of stages of compression for your heat pump system (1 or 2) by pressing the number of STAGES, and using the +/- buttons to increase or decrease.



NOTE: Most heat pump systems have one stage of compression.

- If you have AUXILIARY heat, press the number of stages, use the +/- buttons to select 1-2 stages. The default is **[NONE]**. **NOTE:** The Environ controls up to 3 stages total between pump and AUX.
- If you have AUX, select the type of auxiliary heat that you have, Electric or Gas-Oil. **NOTE:** Most heat pump systems have electric heat strips for auxiliary heat.
- Fan Control is set by the Environ (TSTAT) for heat pumps.
- Press the **HOME** icon to return to the Home screen.



NOTE: For heat pump system your cooling is already configured since the heat pump unit provides both heating and cooling.



Check HVAC System

Follow these procedures to verify you have correctly installed the Environ.

To check Fan (If you connected the G wire - fan relay):



- Press the **FAN** icon on the **HOME** screen and select **ON**.
- Verify that air is blowing from the system. Return fan to **AUTO** selection for normal operation. Press **HOME**.

To check HEAT mode:

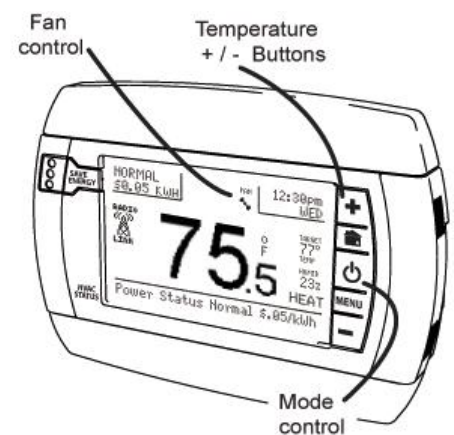
- Press the mode control  and select HEAT.
- Press the **+** button to raise the target temp to 90°F. Allow the system 2 minutes to respond.
- Verify that heat is blowing from the system.
- Return the mode control  to **OFF**. Leave OFF for 4 minutes before checking COOL.



To check COOL mode (do not operate the AC if outside temperature is below 65°F):

1. Press the mode control  and select **COOL**.
2. Press the blue - button to lower the cool target temperature to 50°F. Allow the system five minutes to respond.
3. Verify that cool air is blowing from the system.
4. Return the mode control  to **OFF**.

Congratulations, you have successfully installed your unit. Please continue to the next section to initialize the Environ.

IMPORTANT: After you have labeled and connected your wires, and followed the correct HVAC set-up, if these check procedures do not operate your system call Technical Support for the thermostat at 1-888-200-8514, 8am-midnight Eastern time.

4 Configuring the Environ

Calibration

Your thermostat was calibrated at the factory. We recommend, however, that you calibrate the thermostat to match that of a previous thermostat, or to match another thermostat already in your home.

To Change your Thermostat Calibration:

1. Press **MENU** and then press **CALIBRATE**.
2. Use the **+/-** buttons to adjust the displayed temperature up or down, as desired.
3. The *DELTA FACTOR* that appears on the screen will also automatically increase or decrease for each 1° adjustment. The large display will show the modified temperature reading that will be displayed on the Home screen in normal operation.
4. Press **HOME** to return to the Home screen.

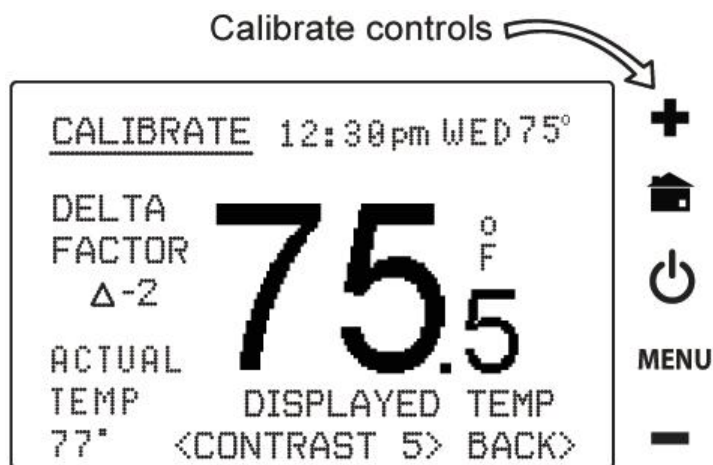

LCD Screen CONTRAST

Your thermostat LCD screen has variable contrast.

To change LCD Screen CONTRAST

1. From the **CALIBRATE** screen, select **CONTRAST** and adjust by pressing the on-screen **<** and **>** controls for best viewing.
2. Press **HOME** to return to the Home screen.

Humidifier

To use the Environ internal humidistat to control an external humidifier unit, connect it as shown. Connect the H terminal to the control leg of the humidifier relay. This allows H to turn the humidifier ON and OFF.

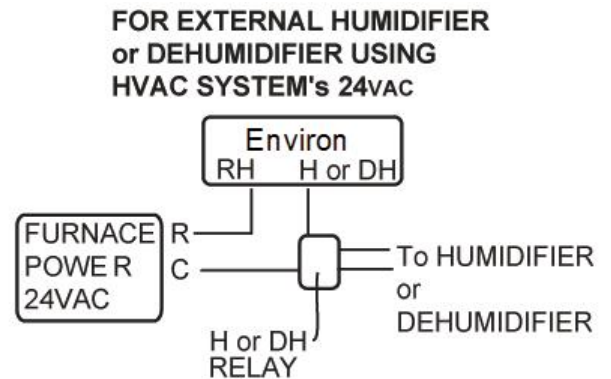

Dehumidifier

To use the Environ internal humidistat to control an external dehumidifier unit, connect it as shown. Connect the DH terminal to the control leg of the dehumidifier relay. This allows DH to turn the dehumidifier ON and OFF.

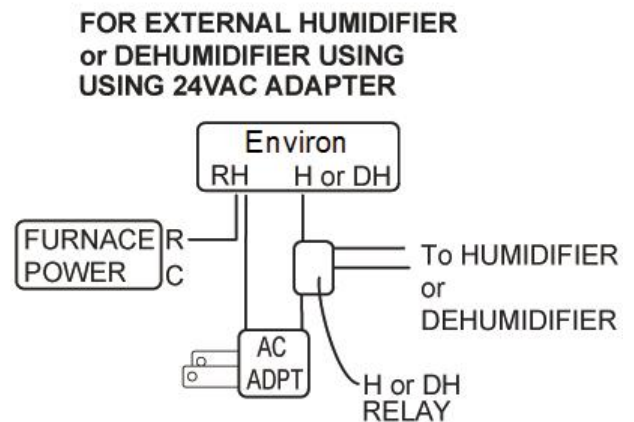

Fresh Air

The Fresh Air feature uses the EX relay to control a baffle on a fresh external air source. Connect the 24VAC baffle to C and EX terminals.

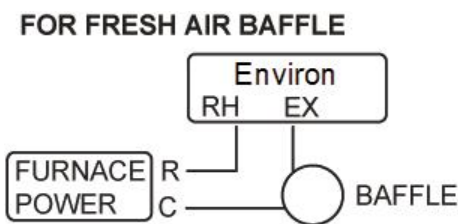

5 Environ Interface to Envoy

The Environ programmable communicating thermostat interfaces to the Enphase Envoy communications gateway using a ZigBee wireless interface. This interface is designed to be plug and play. All that is required is that the Environ and the Envoy be on the same network, and they will automatically mate. Once mated, the Envoy and Environ will pass information between each other once every 5 minutes.

Before setting up your Environ interface to Envoy, ensure that both the Envoy and Environ are properly installed and configured:

Install the Envoy

Ensure the Envoy is installed and operating according to the *Envoy Installation & Operations Manual* included with the Envoy.

Ensure that the firmware version on the Envoy is at least R2.2.0.

Ensure that the Envoy is connected to the Internet and that subscription to the Enlighten web based service is active.

Install Environ

Ensure the Environ is installed and operating according to the installation instructions in this document. Make sure the ZigBee radio is already installed in a radio slot of the Environ.



If multiple zones are in use in the house (for example, one Environ thermostat for downstairs, another for upstairs), ensure that all Environs are in place and operational before proceeding. Multiple Environs can mate to the same Envoy.

Connect Envoy to ZigBee Network

The Envoy will automatically create a ZigBee network when it detects that its radio is present. The Envoy has a Universal Serial Bus (USB) port near the LAN cable connector. To add the radio to Envoy:

1. Find the ZigBee USB stick. This was shipped as part of the Environ kit.
2. Plug the ZigBee USB stick into the Envoy USB port.
3. The Envoy will be open to linking with Environs that are not yet mated with another Envoy for 3 minutes.



Only unmated Environs will link to the Envoy. Once an Environ links to the Envoy, the two will mate, and the Environ will not mate with another Envoy. This prevents the Environ from linking into a different network, e.g. if a neighbor happened to have an Envoy and Environ as well, there will not be a possibility of mating Envoy and Environs between neighbors.

Verify that the Envoy and Environs have Mated

View the LCD screen on the Envoy. As the screens scroll past, you will note one screen titled ENVIRON THERMOSTATS. The second line will display *TOTAL: x ACTIVE: y*, where x is the number of Environs mated to the Envoy and y is the number of Environs that are in active communications with the Envoy. If the number of connected and active Environs matches the number of Environs installed, then the Environs have mated and you will be able to see a message indicating the time of the "Last Enlighten report" on the Environ touch screen. You can now continue to the next step, configuring the Enlighten web page.

Troubleshooting

If the Environ was unable to find the Envoy during the 3 minutes after the ZigBee USB radio is first installed into the Envoy, it may be necessary to restart the mate process. On the Envoy, press and hold the menu button until the display shows *Scan ZigBee Network*. Release the button before the display scrolls to the next item. The Envoy will re-create a new ZigBee network with the Environs. To restart mating on the Environ, press the  icon on the touchscreen, and then start a ZigBee scan.

The radio used in the Environ is designed to have a long range. However some homes have either long distances or enough obstructions where the Environ and the Envoy cannot reach each other. In this case, install a ZigBee repeater (Enphase part number EVRN-RR-01) midway between the Environ and the Envoy. The repeater will pass on any messages it receives. Plug it into any AC wall outlet and press the **Mate** button. When mated and operational, the LED on the repeater will turn green.

If these steps do not result in a successful mate, call Enphase Customer Service at 1 877-797-4743.

6 Operating the Environ through Enlighten

You can control the Environ thermostat directly, or through the web-based Enlighten portal from your personal computer or smartphone. For ease-of-use, we recommend accessing the programming functions through Enlighten rather than on the wall-mounted device.

Below are instructions for accessing the Environ controls through Enlighten. Instructions for programming or adjusting settings on the Environ wall-mounted device itself are provided in Appendix A.

Note: The homeowner may allow his/her installer to view Environ settings in Enlighten, but only the system owner is allowed to change any settings.

Enlighten Monitoring System

There are two main screens for Environ within the Enlighten monitoring system – the **Environ Summary** on the **My System** page and the **Configuration and Programs** page.

Environ Summary on My System page

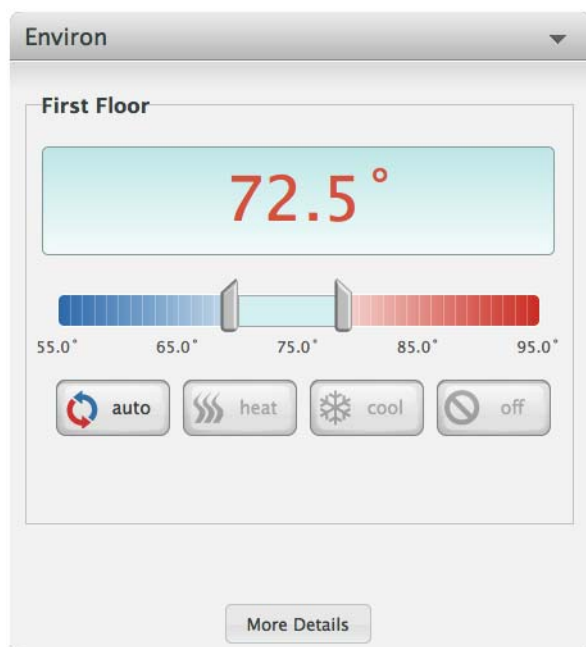

The Environ summary contains the following elements:

Current Temperature: This shows the ambient temperature where the Environ is installed.

Settings: Displays the operating range of the Environ Smart Thermostat and allows you to temporarily override your current program:

- Grab and move the left control to set heater to heat your home to your preferred temperature during cool weather.
- Grab and move the right control to set the air conditioner to cool your home to your preferred temperature during warm weather.

Mode: Displays the current operating mode of the thermostat and allows you to change it.

- **AUTO** – Choose this option to enable the Environ to switch automatically between heat and cool throughout the year. The Environ will switch from HEAT to COOL as needed.
- **COOL** – Choose this option to operate only the cooling portion of your HVAC system. Programmed time slot heat entries will be ignored.
- **HEAT** – Choose this option to operate the heating portion of your HVAC system. Programmed time slot cool entries will be ignored.
- **OFF** - Choose this option to take your HVAC system “off-line.” In this mode your thermostat will not control HVAC functions and your house may experience extreme heat or cold.

More Details: Click this button to access further information and controls on the Environ Configuration and Programs screen.

Configuration and Programs

enlighten
LOG OUT Mark Smith

[SYSTEMS](#) | [ACCOUNT](#) | [SUPPORT](#) | [ADMIN](#)

My System – Environ
 Martinsville, IN 76 F
Normal | [Settings](#) | [Admin](#)

Environ Configuration

First Floor

72.5°

auto
 heat
 cool
 off

Update to Thermostat Complete ✔

Apply program: Work at Home

Last report from thermostat: 3 minutes ago

[Last 10 Updates](#)

Sunday			Monday			Tuesday			Wednesday			Thursday			Friday			Saturday					
Time	Heat	Cool	Time	Heat	Cool	Time	Heat	Cool	Time	Heat	Cool	Time	Heat	Cool	Time	Heat	Cool	Time	Heat	Cool			
06:00 AM	70°	78°	06:00 AM	70°	78°	06:00 AM	70°	78°	06:00 AM	70°	78°	06:00 AM	70°	78°	06:00 AM	70°	78°	06:00 AM	70°	78°	06:00 AM	70°	78°
10:00 PM	62°	82°	10:00 PM	62°	82°	10:00 PM	62°	82°	10:00 PM	62°	82°	10:00 PM	62°	82°	10:00 PM	62°	82°	10:00 PM	62°	82°	10:00 PM	62°	82°

Manage Programs

Normal

Sunday			Monday			Tuesday			Wednesday			Thursday			Friday			Saturday					
Time	Heat	Cool	Time	Heat	Cool	Time	Heat	Cool	Time	Heat	Cool	Time	Heat	Cool	Time	Heat	Cool	Time	Heat	Cool			
06:00 AM	70°	78°	06:00 AM	70°	78°	06:00 AM	70°	78°	06:00 AM	70°	78°	06:00 AM	70°	78°	06:00 AM	70°	78°	06:00 AM	70°	78°	12:00 AM	72°	77°
10:00 PM	62°	82°	08:30 AM	65°	85°	08:30 AM	65°	85°	08:30 AM	65°	73°	08:30 AM	65°	85°	08:30 AM	65°	85°	06:30 PM	70°	78°	10:00 PM	62°	82°
			06:30 PM	70°	78°	06:30 PM	70°	78°	06:30 PM	70°	78°	06:30 PM	70°	78°	06:30 PM	70°	78°						
			10:00 PM	62°	82°	10:00 PM	62°	82°	10:00 PM	62°	82°	10:00 PM	62°	82°	10:00 PM	62°	82°						

Apply Program

SYSTEMS | ACCOUNT | SUPPORT
Privacy | Terms ©2008-2010 Enphase Energy Inc.

The Environ Configuration and Programs screen lets you control your temperature and mode using the same controls as the Environ Summary; see your current programmed settings; see the status of your changes; and set, view, and edit programs.

Changes made on the Environ thermostat and through Enlighten are synchronized approximately every five minutes through the Enphase Envoy communications gateway and the Enlighten portal.

Environ Configuration

Status of last update

The Environ Configuration screen displays the status of your last update. The possible statuses are:

- **Pending:** The operation has not yet been sent through the Envoy to the thermostat.
- **Complete:** The operation succeeded.
- **Unsuccessful:** The operation failed.

You can click on “Last 10 Updates” to see the status of the last 10 messages for the thermostat that were sent to the Envoy.

Manage Programs

In the **Manage Programs** section you can customize daily or weekly programs to automate temperature settings for your thermostat. The screen includes the following elements and functions:

- **Program:** This lets you select a different program to view or modify. In addition to the current thermostat program, there are three default programs that you can customize and apply to your Environ thermostat: Normal, Work at Home, and Vacation.
- **Calendar:** Each day of the week is displayed along with the programmed time slots for that day. Each time slot represents your comfort range for that time. For instance, the screenshot above shows that the homeowner’s current program has been created to suit the following schedule:

Weekdays:

Time
6:00 AM
10:00 PM

Comfort Range
70° – 78° F
62° – 82° F

Editing a Program

To edit a program, select the program you want to modify from the menu. This will display that program’s schedule for each day of the week. Click the “edit” link next to the day of the week that you would like to modify. This will take you to the Edit Program screen.

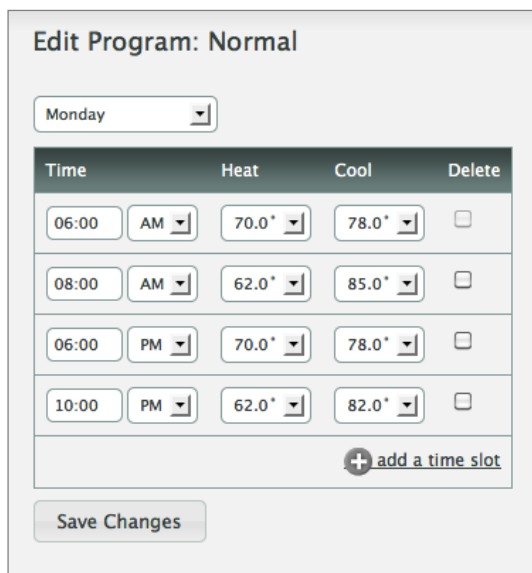

Edit Program: Normal

Monday

Time	Heat	Cool	Delete
06:00 AM	70.0°	78.0°	<input type="checkbox"/>
08:00 AM	62.0°	85.0°	<input type="checkbox"/>
06:00 PM	70.0°	78.0°	<input type="checkbox"/>
10:00 PM	62.0°	82.0°	<input type="checkbox"/>

[+ add a time slot](#)

Save Changes

Day: This lets you select the day or range of days that you wish to modify.

Schedule: This shows the programmed time slots for the current day. Each time slot consists of a starting time and a comfort range defined by a heat and cool point. Add a time slot to the schedule by clicking the “add time slot” link. You may add up to seven programmed time slots per day.

To save your changes, click the “Save Changes” button.

Applying a Program

To change the current program for an Environ, go to the Configuration and Programs screen and select the desired program in the program menu. Then click the ‘Apply Program’ button to apply the program to the thermostat.

Smartphone Access

The Summary and Configuration function above may be accessed via the smartphone version of the Enlighten Environ interface. Use your smartphone's web browser to navigate to Enlighten. Log in, and the Enlighten system will automatically detect your smartphone device and display a mobile version.

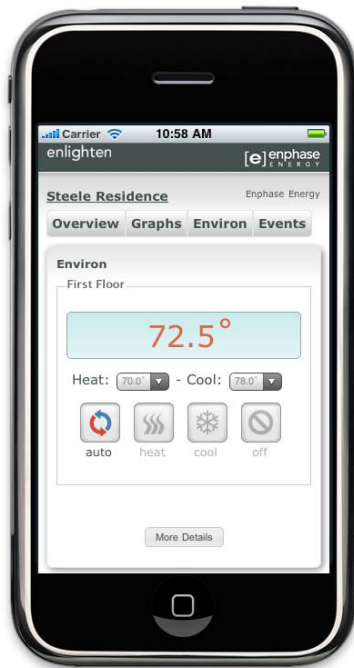

7 Environ Local Interface

To program or adjust your Environ on the device itself, simply press your finger or the stylus firmly to the screen. The screen will automatically light up and you will hear a “beep.” The screen will respond differently to different types of touches, so you may want to experiment with both your finger and with the included stylus to find the method that works best for you.

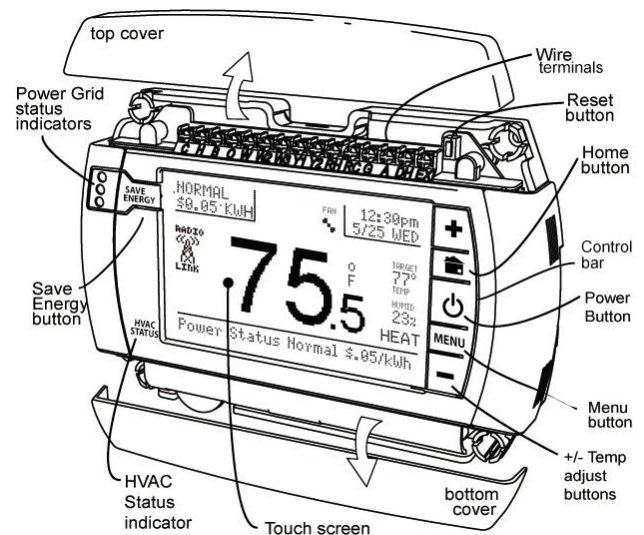

Note: The touchscreen stylus is stored on the left side of the Environ, near the top. To remove the stylus, firmly grasp the top of the stylus, which protrudes slightly beyond the side edge of the Environ case, and pull straight out to the left. For your convenience, it may also be stored in the corresponding location on the right side of Environ.





Instructions included in this section cover the operation of the Environ Smart Thermostat directly on the device itself. To control the Environ via Enlighten, log in to your Enlighten portal using your standard login credentials, and follow the simple-to-use instructions on the screen.

Control Screens

Before you operate the Environ, please become familiar with these basic control screens. All the Environ functions are accessed through these screens. The Environ touch screen technology allows you to select (by pressing) an item and change it using the +/- buttons on the control bar. All user inputs use this method. Press the button to change the input.

Home Screen

The **Home** screen displays when the unit is operating. Pressing the green HOME icon  on the control bar will always return you to this screen. To set a Mode:

Press the **Power** icon  on the control bar. Press the desired mode from the choices displayed at the bottom **COOL, HEAT, AUTO, or OFF**. Press **HOME** when done.

Set the time by pressing the hour or minute and the +/- buttons to change. Your Environ is now controlling your **HVAC**.

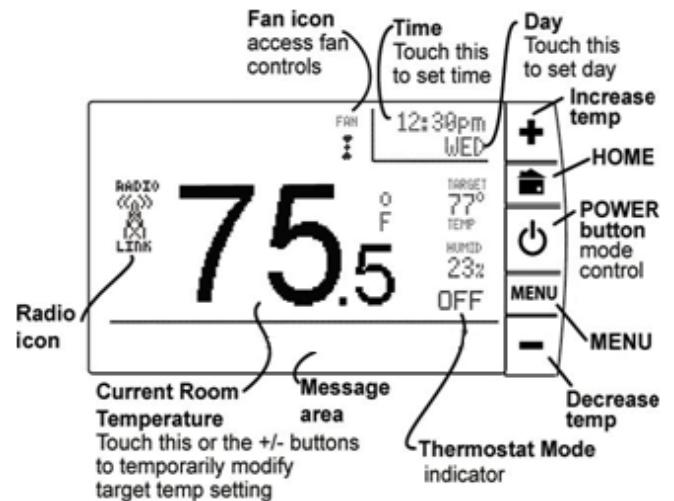

Manual Screen

The **Manual Screen** control screen is where you can make temporary changes to your Environ's operation. The Environ has 6 manual override commands. These are accessed by pressing the +/- buttons or pressing the current temperature on the HOME screen.

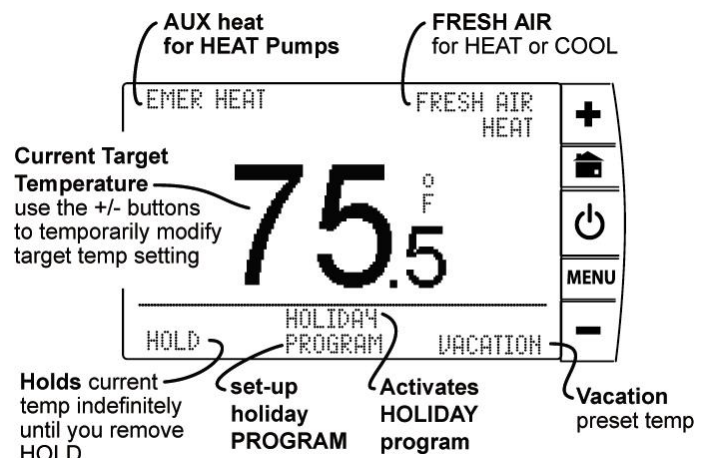

Temporary OVERRIDE -

- Press the +/- buttons to select your desired temporary Target Temperature.
- Press **HOME** to return to operation.

The **TEMPORARY** icon will display indicating you have modified the Target Temperature for the current Time Slot only.

Hold - This will hold the target temperature you set indefinitely, until you turn it off. Take care using the **HOLD** function. To set a hold, press **HOLD** to initiate a hold temperature. You can use the +/-

buttons to select your hold temperature. The **Hold** icon will display on the HOME screen indicating you have changed the Target Temperature. The system will **HOLD** this temperature until you return to this screen and de-select **HOLD**, by pressing it. HOLD is also canceled when you set the mode to **OFF**.

Holiday Program – (This feature is not supported once Enlighten is connected to the Environ – use the Enlighten interface for holiday programming.) This is a single program that repeats day after day until you turn it off. It supersedes the weekly program. To modify it press PROGRAM on the MANUAL screen. It uses the Calendar method for programming. Refer to page 30 for more information.

Vacation - (This feature is not supported once Enlighten is connected to the Environ – use the Enlighten interface for vacation programming.) This function will hold a pre-set temperature until you turn it off. The preset is saved for next time.

Fresh Air - If you have a fresh air baffle connected to the EX terminal, the Environ will use this outside air source as the 1st stage of heating or cooling. This feature is useful in desert climates where outside air temp can change very quickly or just to freshen indoor air quality.

Emer Heat - This is available if you have a heat pump with auxiliary heat. When you select this, your heat pump is disabled and auxiliary heat is your sole source of heat. This manual override setting stays active until you turn it off. This command is not displayed if you do not have a heat pump. Remember auxiliary heat is more expensive than the heat pump.

Menu Screen

The **Menu** screen is the gateway to many functions of the Environ. It is displayed when you press the purple **MENU** button on the control bar to the right side of the screen.

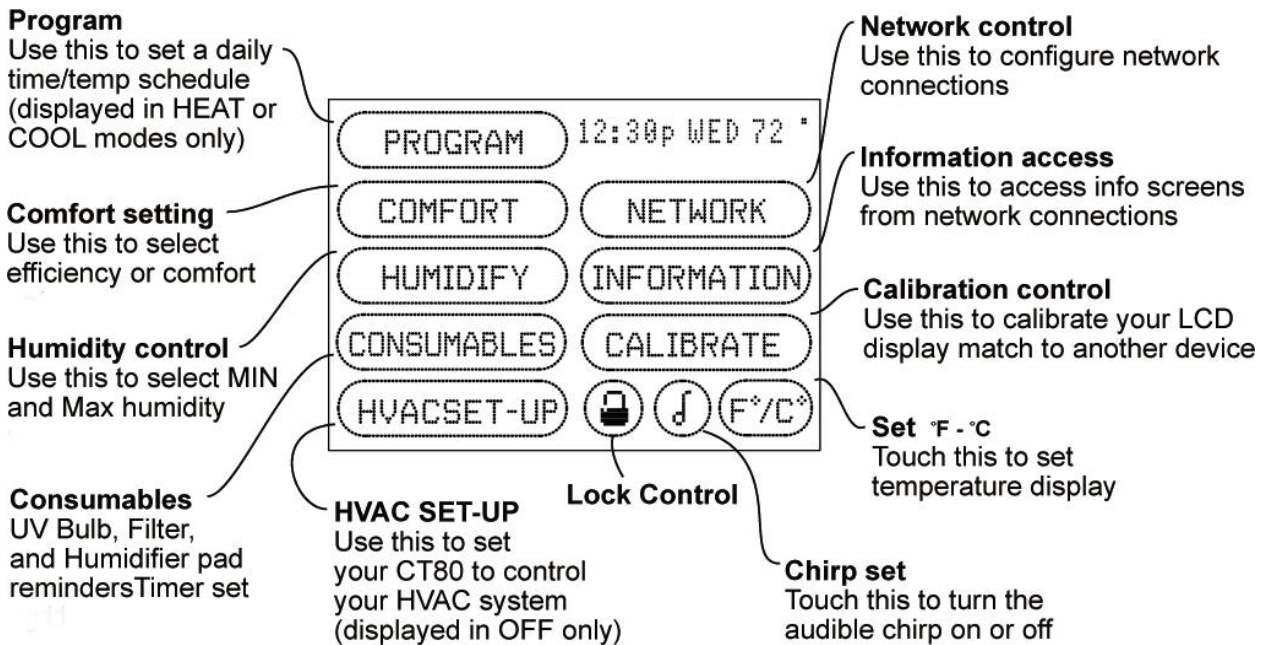

Menu Functions

PROGRAM

Program Settings

The Environ is designed for fast and easy programming with a simple, on-screen interview. Just answer the questions and the Environ takes care of the rest. A calendar option is also available for fine-tuning. HEAT and COOL are programmed separately.



You may also program the Environ through Enlighten. To do so, log in to your Enlighten portal using your standard login credentials, and follow the simple-to-use instructions on the screen to access the Programs function. The method below may be useful if the thermostat is installed prior to commissioning the Envoy into Enlighten.

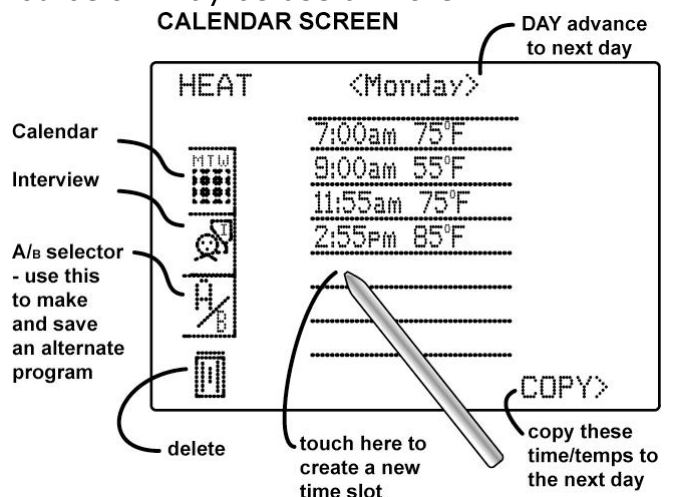



Calendar Programming Method

You can use the **Calendar** screen to review your current Environ schedule, or to make changes after programming in Interview mode.

To create a whole new program:

1. With the Environ in HEAT or COOL mode, press **MENU** and then press **PROGRAM** in the upper left of the screen.
2. Press the **CALENDAR** icon  on the left side of the screen. A schedule of time slots with temperatures for the day appears on the screen.
3. Select a time period or temperature by pressing it, and use the +/- buttons to adjust up or down. Press and hold down +/- buttons for faster scrolling.
4. You can add up to seven additional time slots a day by pressing a blank line, and then adjusting the time and temperature with the +/- buttons. To delete a time slot, highlight and then press the **TRASH CAN** icon in the lower left of the screen.
5. Press the left < or right > arrows next to the day of the week to go to the next or previous day and continue programming. To copy one day's programming to the next day, press **COPY>** on the bottom right of the screen. The information for the current day will be copied to the next day and will appear on the screen.
6. Press **HOME** to return to the Home screen.



A/B program: The Environ can hold 2 complete weekly programs in memory. These programs are designated 'A' and 'B'.

Programs entered in through the Calendar Programming Method are stored in Program 'B' and are available to be uploaded to Enlighten. Enlighten can load and access Program 'B' only. A programming method through an interview is also available, but programs created this way are stored in Program 'A' and are not available to Enlighten

COMFORT

Comfort Settings

The Comfort Settings on the Environ allow you to maintain consistent comfort with the highest levels of temperature control precision, accuracy and energy efficiency.

HVAC CYCLING: This feature allows you to set the desired variance in temperature between the Environ setting and the room temperature required before the heating or cooling system will turn on—from 0.5° to 2.0° F (.25° to 1° C).

For example, if HVAC CYCLING is set to 2.0° F and the Environ is set to 70°F, the heat cycle will not activate until the room temperature drops to 68°. Similarly, the cooling system will not activate until the room temperature increases to 72°F. The HVAC shuts off at the target.

To set/adjust HVAC CYCLING:

1. Press Menu and then press **COMFORT**.
2. Press the temp offset setting.
3. Use the +/- buttons to raise or lower the variance setting—from 0.5° to 2.0° F.
4. Press **HOME** to return to the Home screen.

2ND STAGE ON AT: This feature allows you to adjust the settings that control second stage heating and cooling depending upon the climate you live in. This can be modified for maximum efficiency or comfort. It is displayed if you have configured a multistage system in HVAC SET-UP.

To set/adjust 2ND STAGE ON AT:

1. Press **Menu** and then press **COMFORT**.
2. Press and highlight the user setting (next to 2ND STAGE ON AT).
3. Use the +/- buttons to raise or lower the setting from 2.0° to 4.5°F (1° to 2.5° C).
4. Press **HOME** to return to the Home screen.



Chirp set

Press this icon to turn the audible chirp sound on or off.



F/C Set

Press this icon to toggle the temperature display scale between °F and °C.

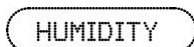

Humidity

The Environ has a humidistat to control an external humidifier for humidifying by the H terminal.

HUMIDIFIER: To set a minimum humidity level with a humidifier installed in the HVAC:

1. From the **HOME** screen, press **MENU**, then press **HUMIDITY**.
2. Toggle **HUMIDIFR** from **<OFF>** to **<W/HEAT>**.
3. Press **MIN --%** and use the **+/-** buttons to set the desired minimum humidity level.
4. The Environ can be toggled **<ALWAYS>** run the humidifier when the humidistat calls for humidity (fan also runs) or can be set to run only when the humidistat is calling for humidity and the heat is also running **<W/ HEAT>**.

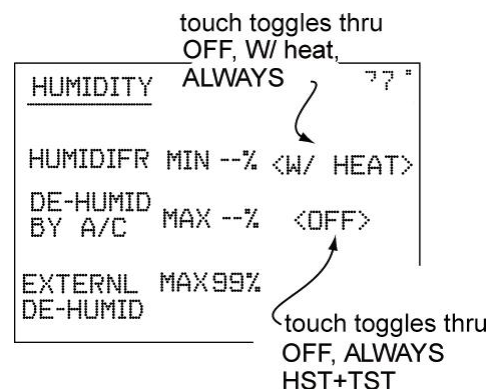

DE-HUMID BY A/C: The Environ's humidistat can also control the Air Conditioner for dehumidifying. To set a maximum humidity level (using the air conditioner):

1. Press **MENU**, then press the **HUMIDITY**, then view **DE-HUMID by A/C**.
2. Press **MAX --%** and use the **+/-** buttons to set the desired maximum humidity level. **Note:** You cannot change MAX humid % until you set it to **ALWAYS** or **HST+TST**.
3. The Environ can be toggled to **<ALWAYS>** run the air conditioner when the humidistat calls to dehumidify or can be set to run the air conditioner only when the humidistat calls to

dehumidify and the thermostat is also calling for COOL
<HTS+TST> (HST=humidistat, TST=thermostat).

EXTERNAL DE-HUMID: The Environ humidistat can also control an external dehumidifier, if you have a dehumidifier unit installed in your HVAC system. Connect it to the DH terminal.

To set a maximum humidity level:

1. Press **MENU**, then press the HUMIDITY.
2. Press **MAX --%** and use the +/- buttons to set the desired maximum humidity level.
3. Press **HOME** to return to the Home screen.

CONSUMABLES

Consumables

Consumables are the parts of your HVAC system that must periodically be replaced, such as filters and UV bulbs. The Environ keeps monitors system run times, and can be programmed to remind you when consumables, such as air filters, humidifier pads and UV bulbs, should be checked and/or changed.

- **HUM PAD:** Run time of humidifier
- **AIR FILTER:** Run time of HEAT+COOL
- **UV BULB:** Real time

CONSUMABLES 12:30p WED 75°		
	CHECK ALERT	RUN TIME
HUM PAD	00wks	00wks
AIR FILTER	00wks	00wks
UV BULB	00wks	00wks

To set/adjust CHECK CONSUMABLES ALERTS:

1. Press Menu and press **CONSUMABLES**, and select a **CHECK ALERT** to set.
2. Select the number of weeks in the **CHECK ALERT** column for that item, and use the +/- buttons to raise or lower the setting.
 - Alerts may be scheduled from 0 to 99 weeks.
3. Repeat for each item included in your system.
 - If your system does not include a listed item, leave the **CHECK ALERT** at 00wks.
4. Press **HOME** to return to the Home screen.

When the Run Time for a given item reaches the limit you have set, the Environ will show you a reminder in the message area of the Home screen.

HVAC Set-up

HVACSET-UP This function allows you to configure the Environ to control your HVAC system. The Environ will control most residential systems. Take care to correctly set-up the Environ. Incorrect set-up can result in damage to your HVAC system.

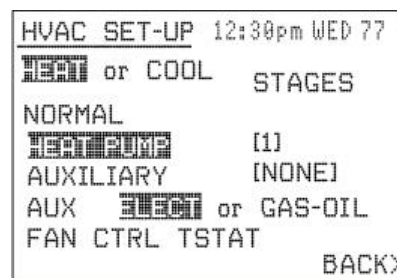

IMPORTANT: Make sure the Environ is powered up and is in the OFF mode before set-up. (To turn your thermostat **OFF**, press the Power button  and select **OFF**.) Heating and cooling systems must be configured separately.

Set-up for Normal Heat Systems (not a heat pump):

1. Press the purple **MENU** button on the control bar and then press **HVAC SET-UP**.
2. Press to highlight **HEAT** in the upper left corner of the display.
3. Press to highlight **NORMAL**.
4. Select the appropriate number of stages for your heating system (from 1 to 3) by pressing the number of STAGES to highlight, and using the +/- buttons to increase or decrease.
5. Press the appropriate **FAN CONTROL** setting. Select **HVAC** if your heating system controls the fan (appropriate for most gas, oil, propane, and similar furnaces). Select **TSTAT** if you want the thermostat to control the fan (for most electric heating systems).
6. Continue to configure **COOL** or press **HOME** to return to the Home screen.

Set-Up for Normal A/C cooling systems:

1. Press **MENU** and then press **HVAC SET-UP**.
2. Press and highlight **COOL** in the upper left corner of the display.
3. Select the number of stages of compression for your cooling system (1 or 2) by pressing the number of **STAGES** and using +/- buttons to change. **NOTE:** If your system does not have A/C, select **NONE** as your number of stages to discontinue on-screen cooling messages.
4. Press to select the appropriate **FAN CONTROL** setting **HVAC** or **TSTAT**. **NOTE:** Most cooling systems require that the thermostat **TSTAT** control the fan.

this range press **RANGE +/-** and use the +/- buttons to adjust up and down.

FULL: No changes can be made.

Once locked, the Environ will respond to a limited set of manual commands.

To UNLOCK

1. Press **MENU**, press and hold the **LOCK** icon  for 10 seconds.
2. Press **LOCK OFF**.
3. Press **HOME** to return to the Home screen.

CALIBRATE **Calibrate**
Your thermostat was accurately calibrated at the factory to $\pm 1^{\circ}$ F of the actual ambient temperature. You do have the option, however, to change the display temperature (from $\pm 1 - 9^{\circ}$ F) to match that of a previous thermostat, or to match another thermostat already in your home.

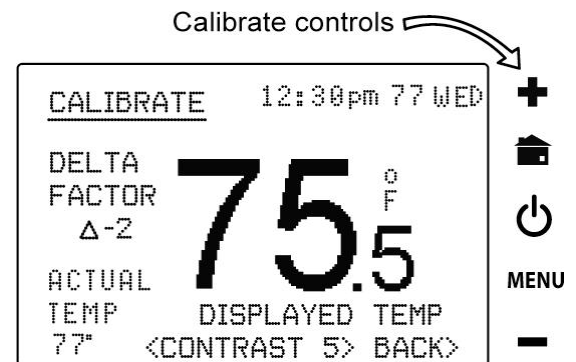

To change your Thermostat Calibration:

1. Press **MENU** and then press **CALIBRATE**
2. Use the +/- buttons to adjust the displayed temperature up or down, as desired.
3. The DELTA FACTOR that appears on the screen will also automatically increase or decrease for each 1° F (or 0.5° C) adjustment. The large display will show the modified temperature reading that will be displayed on the **HOME** screen and used as the new room temp.
4. Press **HOME** to return to the Home screen.

LCD Screen CONTRAST

To change LCD Screen CONTRAST:

1. From the CALIBRATE screen, select **CONTRAST** and adjust by pressing the on-screen < and > controls for best viewing.
2. Press **HOME** to return to the Home screen.

Save Energy Button

The Save Energy feature on the Environ provides a simple, easy-to-use way to help you manage your energy use. **SAVE ENERGY** automatically adjusts your target temperature up (in COOL) or down (in HEAT) by a specified value degrees. The default is four degrees.

To use Save Energy:

1. Press the **SAVE ENERGY** button in the upper left corner of the unit. The screen will now read *Save Energy Δ 4°* and the Target Temperature will adjust by that offset.
2. Use the +/- buttons to change the offset. Range 2°-9°F [1°-5°C].
3. To return to normal operation, press the **Save Energy** button again, and the **TARGET TEMP** will return to the programmed temperature.

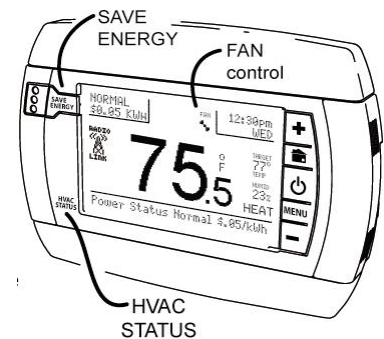

Fan control

To view the fan status, press the **FAN** icon located at the top center of the **HOME** screen.

AUTO: The fan control is normally set to **AUTO** mode, meaning that the fan operates automatically, only when the HVAC system is also running.

CIRC: The **CIRC** function allows your fan to automatically circulate air for up to nine minutes per hour for better indoor air quality and efficiency.

FRESH: If your HVAC system has a fresh air baffle, press **FRESH** to use fresh air with HVAC. This works with AUTO or ON. The fresh air baffle must be connected to the EX terminal on the Environ.

ON: To manually turn **ON** the fan, press the **FAN** icon and then press **ON**.



The FAN icon will begin turning and the fan will run continuously until switched to **AUTO**. The fan **ON** function is available in OFF mode to allow simple ventilating.

Power Button and Mode selection

The power button brings up your mode selection options:

COOL: This will operate the cooling portion of your HVAC system until it is turned off.

HEAT: This will operate the heating portion of your HVAC system until it is turned off.

AUTO: The Environ TRUE AUTO mode switches automatically between heat and cool throughout the year. The Environ will switch from HEAT to COOL as needed.

OFF: This takes your HVAC system off-line, and it will not control HVAC functions.

HVAC Status

The HVAC STATUS indicator shows what HVAC function is active. It glows orange when the HEAT function is active, blue when the COOL function is active, and green when the fan is active. These indicators can combine, where orange-green indicates HEAT-FAN and BLUE-GREEN indicates COOL-FAN.

Reset Button

The **RESET** button re-boots the Environ processor. It does not affect the user programs that have been stored in permanent memory.

NETWORK

Network

The **NETWORK** button allows you to identify the network you are connected with and further manage your settings. The Environ does not require any manipulation of this page to mate with the Envoy and Enlighten.

RTM-1 Radio Module:

The Environ ships with a ZigBee radio module installed into it. No additional manipulation should be required.

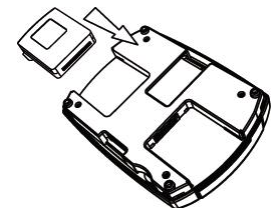

INFORMATION

Information

This represents future capability on the Environ. This Menu function displays information and interactive screens from a network source.

Wire Reference Chart

<u>Your Wires</u>	<u>Environ Terminal</u>
R or V or VR	RH and RC Single power for HEAT and COOL
RH or 4	RH Power for HEAT (RH not connected to RC jumper clip removed)
RC	RC Power for COOL (RH not connected to RC jumper clip removed)
W	W Heat control
W2	W2 2nd stage HEAT or heat pump auxiliary heat
W3	W3 3rd stage HEAT or 2nd stage of 2 stage auxiliary heat
?	A 3rd wire for zoned hot water heat (see zoned systems pg 12)
Y	Y COOL control or 1st stage compression for heat pump.
Y2	Y2 2nd stage COOL control or 2nd stage compression for a heat pump
G or F	G FAN control
C or X	C Common 24VAC power (to power thermostat) NOTE: TRANE uses B for this connection
E	n/a Emergency heat (do not connect, tape off)
L	n/a System monitor (do not connect, tape off)
T	n/a Outdoor sensor (do not connect, tape off)
H	External Humidifier
DH	External Dehumidifier
EX	External fresh air baffle
B or	B Heat pump changeover (cool to heat, powered in heat)
O	O Heat pump changeover (heat to cool, powered in cool)
B and O	IMPORTANT: If there are both B and O wires (Trane pump products) DO NOT CONNECT B to B terminal, connect B to C terminal. If not a Trane product tape off B.
<i>Lennox Heat</i>	<i>Pump</i>
V or VR or R	RH Power for HEAT
M or Y	Y
Y or W or W2	W2
F or G	G
R or O	OX or X2 or C

Trane Products

B	C
W or W1 or X2	W2

Zoned Systems Wire Reference Chart

Your Wires Environ Terminal

2 wire Zoned Hot Water

R	RH
W	W

3 wire Zoned Hot Water, Motor Driven Valves

R or 5	RH (power)
W or 4	W (heat ON)
Y or G or 6 (the 3 rd wire)	A (heat OFF)

3 wire Zoned Hot Water, Solenoid Driven Valves

R	RH (power)
W	A (heat ON)
Y or G (the 3 rd wire)	W (heat OFF)

8 Appendix

Limited Warranty

Enphase Energy Inc. ("**Enphase**") has developed the Environ Smart Thermostat, that is designed to withstand normal operating conditions when used for its originally intended purpose in compliance with the Enphase User Manual supplied with the originally shipped system. The Enphase limited warranty ("**Limited Warranty**") covers defects in workmanship and materials of the Environ Smart Thermostat ("**Defective Product**") for a period of one (1) year from the date of original purchase of such Environ Smart Thermostat at point of sale to the originally-installed end user location (the "**Warranty Period**"). During the Warranty Period, the warranty is transferable to a different owner as long as the Environ Smart Thermostat remains installed at the originally-installed end user location.

During the Warranty Period, Enphase will, at its option, repair or replace the Defective Product free of charge, provided that Enphase through inspection establishes the existence of a defect that is covered by the Limited Warranty. Enphase will, at its option, use new and/or reconditioned parts in repairing or replacing the Defective Product. Enphase reserves the right to use parts or products of original or improved design in the repair or replacement of Defective Product. If Enphase repairs or replaces a Defective Product, the Limited Warranty continues on the repaired or replacement product for the remainder of the original Warranty Period or ninety (90) days from the date of Enphase's return shipment of the repaired or replacement product, whichever is later.

The Limited Warranty covers both parts and labor necessary to repair the Defective Product, but does not include labor costs related to un-installing the Defective Product or re-installing the repaired or replacement product. The Limited Warranty also covers the costs of shipping repaired or replacement product from Enphase, via a non-expedited freight carrier selected by Enphase, to locations within the United States (including Alaska and Hawaii) and Canada, but not to other locations outside the United States or Canada. The Limited Warranty does not cover, and Enphase will not be responsible for, shipping damage or damage caused by mishandling by the freight carrier and any such damage is the responsibility of the freight carrier.

To obtain repair or replacement service under this Limited Warranty, the customer must comply with the following policy and procedure:

- All Defective Product must be returned with a Return Merchandise Authorization Number (RMA) which customer must request from Enphase. Before requesting the RMA, however, the customer should contact an Enphase technical support representative to evaluate and troubleshoot the problem while the Environ Smart Thermostat is in the field, since many problems can be solved in the field.

- If in-field troubleshooting does not solve the problem, Customer may request the RMA number, which request must include the following information:
 - Proof-of-purchase of the Defective Product in the form of (1) the dated purchase receipt from the original purchase of the product at point of sale to the end user, or (2) the dated dealer invoice or purchase receipt showing original equipment manufacturer (OEM) status, or (3) the dated invoice or purchase receipt showing the product exchanged under warranty
 - Model number of the Defective Product.
 - Serial number of the Defective Product.
 - Detailed description of the defect.
 - Shipping address for return of the repaired or replacement product.
- All Defective Product authorized for return must be returned in the original shipping container or other packaging that is equally protective of the product.
- The returned Defective Product must not have been disassembled or modified without the prior written authorization of Enphase.

The Limited Warranty does not cover normal wear and tear of Environ Smart Thermostat or costs related to the removal, installation, or troubleshooting of the customer's electrical systems. The Limited Warranty does not apply to, and Enphase will not be responsible for, any defect in or damage to any Environ Smart Thermostat: (1) that has been misused, neglected, tampered with, altered, or otherwise damaged, either internally or externally; (2) that has been improperly installed, operated, handled or used, including use under conditions for which the product was not designed, use in an unsuitable environment, or use in a manner contrary to the Enphase User Manual or applicable laws or regulations; (3) that has been subjected to fire, water, generalized corrosion, biological infestations, acts of God, or input voltage that creates operating conditions beyond the maximum or minimum limits listed in the Environ Smart Thermostat specifications, including high input voltage from generators or lightning strikes; (4) that has been subjected to incidental or consequential damage caused by defects of other components of the HVAC system; or (5) if the original identification markings (including trademark or serial number) of such Environ Smart Thermostat have been defaced, altered, or removed. The Limited Warranty does not extend beyond the original cost of the Environ Smart Thermostat.

THE LIMITED WARRANTY IS THE SOLE AND EXCLUSIVE WARRANTY GIVEN BY ENPHASE AND, WHERE PERMITTED BY LAW, IS MADE EXPRESSLY IN LIEU OF ALL OTHER WARRANTIES, EXPRESS OR IMPLIED, STATUTORY OR OTHERWISE, INCLUDING, WITHOUT LIMITATION, WARRANTIES OF TITLE, QUALITY, MERCHANTABILITY, FITNESS FOR A PARTICULAR PURPOSE OR NON-INFRINGEMENT OR WARRANTIES AS TO THE ACCURACY, SUFFICIENCY OR SUITABILITY OF ANY TECHNICAL OR OTHER INFORMATION PROVIDED IN

MANUALS OR OTHER DOCUMENTATION. IN NO EVENT WILL ENPHASE BE LIABLE FOR ANY SPECIAL, DIRECT, INDIRECT, INCIDENTAL OR CONSEQUENTIAL DAMAGES, LOSSES, COSTS OR EXPENSES HOWEVER ARISING, WHETHER IN CONTRACT OR TORT, INCLUDING WITHOUT LIMITATION ANY ECONOMIC LOSSES OF ANY KIND, ANY LOSS OR DAMAGE TO PROPERTY, OR ANY PERSONAL INJURY.

To the extent any implied warranties are required under applicable law to apply to the Environ Smart Thermostat, such implied warranties shall be limited in duration to the Warranty Period, to the extent permitted by applicable law. Some states and provinces do not allow limitations or exclusions on implied warranties or on the duration of an implied warranty or on the limitation or exclusion of incidental or consequential damages, so the above limitation(s) or exclusion(s) may not apply. This Limited Warranty gives the customer specific legal rights, and the customer may have other rights that may vary from state to state or province to province.

Enphase Energy Inc.

201 1st Street

Petaluma, CA 94952

Phone: 707-763-4784

TOLL FREE: 877-797-4743

Fax: 707-763-0784

www.enphaseenergy.com

info@enphaseenergy.com