

# Calculating AC Line Voltage Drop for M215 Microinverters with Engage™ Cables

---

## Contents

- Overview.....1
- Voltage Rise for M215s with the 240 VAC Engage Cable .....2
- Voltage Rise for M215s with the 208 VAC Engage Cable .....3
- Engage and Wire Sizing Overview .....4
- What Contributes to Voltage Rise .....4
- VRise Calculations by Wire Section .....5
- Internal VRise within the Engage Cable .....6
- Advantages of Center-Feeding the AC Branch Circuits.....7
- Calculating Total Voltage Rise for Single-Phase Installations .....8
- Voltage Rise for M215s with the 240 VAC Engage Cable .....8
- Sample Calculation.....8
- Summary of Calculations for 240 VAC Applications ..... 10
- Calculating Total Voltage Rise for Three-Phase Installations..... 10
- Voltage Rise for M215s with the 208 VAC Engage Cable ..... 10
- Summary of Calculations for 208 VAC Applications ..... 12
- Conclusion..... 12

## Overview

This paper describes the methods for calculating the AC line voltage drop (VDrop) for dedicated PV branch circuits. It is common to refer to these calculations as Voltage Drop Calculations, but in fact, PV systems generate electricity, and the voltage actually rises (VRise) at the AC terminals of the microinverters. This is because the microinverters are a current source rather than a voltage source or a load.

The IEEE-1547 standard requires that utility interactive inverters cease to export power if the voltage measured at the Point of Common Coupling (PCC) exceeds +10% or -12% of nominal. The PCC is generally at the main electric service meter. A microinverter’s point of reference for voltage measurement is at each microinverter’s AC output. Since the microinverter is located at the array, the distance to the PCC could be substantial. Undersized conductors can cause the voltage measured at the microinverter to be outside of the IEEE limits, which then causes the microinverter to enter an AC Voltage Out Of Range (ACVOOR) condition (at which point it ceases to export power).

The application of proper voltage rise calculations will help to avoid nuisance trip issues due to high line voltage conditions. Moreover, less resistance in the wiring will result in less heat at the terminals, less power loss, and improved performance of the PV system.

Enphase Microinverters, like all utility interactive inverters, sense the voltage and frequency from the AC grid and are required to cease exporting power when the voltage or frequency

from the grid is either too high or too low. In addition, voltage rise (VRise) within system wiring can combine with the necessity to match AC Grid voltage and cause the microinverters to sense an over voltage condition and cease operation.

Although the Enphase Engage Cable has been optimized for minimal VRise, it is still important to calculate VRise for the entire system, from the array to the PCC. Enphase recommends that the total VRise in the AC wiring be less than 2%, which includes less than 1% VRise in the Engage Cable. The application of proper VRise calculations to your site plan will help to prevent nuisance trip issues and will result in less resistive heat at the terminals, reduced power loss, and improved performance of the PV system. Using the examples in this paper, you will be able to calculate VRise values for your project.

All components within the system wiring will contribute to resistance and must be considered when calculating the total VRise. As all of these resistances are in series, they are cumulative. For a single-phase system, the total resistance is equal to two times the one-way resistance. For a three-phase system, each of the three line currents and resistances must be calculated and then combined, as outlined within. In addition, wire sizing is very important as use of undersized conductors can result in nuisance tripping of the microinverters' overcurrent protection devices (OCPD).

Since the VRise is nonlinear, reducing the number of microinverters in the branch circuit greatly reduces the voltage measured at the last microinverter in an end-fed branch. One of the best ways to minimize voltage rise in a fully-populated branch is to center-feed the branch, that is, divide the circuit into two sub-branch circuits protected by a single OCPD.

## Voltage Rise for M215s with the 240 V<sub>AC</sub> Engage Cable

### Internal VRise within 240 VAC, 4 wire, 1.0m portrait Engage Cables for M215s, end-fed:

Microinverters per Branch in Portrait																	
	1	2	3	4	5	6	7	8	9	10	11	12	13	14	15	16	17
VRise	0.01	0.04	0.08	0.13	0.19	0.27	0.35	0.46	0.57	0.70	0.84	0.99	1.15	1.33	1.52	1.72	1.94
%	0.01	0.02	0.03	0.05	0.08	0.11	0.15	0.19	0.24	0.29	0.35	0.41	0.48	0.55	0.63	0.72	0.81
Current	0.90	1.79	2.69	3.58	4.48	5.38	6.27	7.17	8.06	8.96	9.85	10.75	11.65	12.54	13.44	14.33	15.23

### Internal VRise within 240 VAC, 4 wire, 1.7m landscape Engage Cables for M215s, end-fed:

Microinverters per Branch in Landscape																	
	1	2	3	4	5	6	7	8	9	10	11	12	13	14	15	16	17
VRise	0.02	0.06	0.13	0.21	0.31	0.44	0.59	0.75	0.94	1.15	1.38	1.64	1.91	2.20	2.52	2.85	3.21
%	0.01	0.03	0.05	0.09	0.13	0.18	0.24	0.31	0.39	0.48	0.58	0.68	0.80	0.92	1.05	1.19	1.34
Current	0.90	1.79	2.69	3.58	4.48	5.38	6.27	7.17	8.06	8.96	9.85	10.75	11.65	12.54	13.44	14.33	15.23

### Internal VRise within 240 VAC, 4 wire, 1.0m portrait Engage Cables for M215s, center-fed:

Microinverters per Sub-Branch (Two Sub-Banches) in Portrait																	
	1	2	3	4	5	6	7	8	9								
VRise	0.01	0.04	0.08	0.13	0.19	0.27	0.35	0.46	0.57								
%	0.01	0.02	0.03	0.05	0.08	0.11	0.15	0.19	0.24								
Current	0.90	1.79	2.69	3.58	4.48	5.38	6.27	7.17	8.06								

**Internal VRise within 240 VAC, 4 wire, 1.7m landscape Engage Cables for M215s, center-fed:  
Microinverters per Sub-Branch (Two Sub-Branches) in Landscape**

	1	2	3	4	5	6	7	8	9
VRise	0.02	0.06	0.13	0.21	0.31	0.44	0.59	0.75	0.94
%	0.01	0.03	0.05	0.09	0.13	0.18	0.24	0.31	0.39
Current	0.90	1.79	2.69	3.58	4.48	5.38	6.27	7.17	8.06

**Voltage Rise for M215s with the 208 V<sub>AC</sub> Engage Cable**

**Internal VRise within 208 VAC, 5 wire, 1.0m portrait Engage Cables for M215s, end-fed:  
Microinverters per Branch in Portrait**

	3	6	9	12	15	18	21	24
VRise	0.08	0.21	0.39	0.65	0.96	1.35	1.79	2.30
%	0.04	0.10	0.19	0.31	0.46	0.65	0.86	1.11
Current	1.79	3.58	5.37	7.16	8.95	10.74	12.53	14.32

**Internal VRise within 208 VAC, 5 wire, 1.7m landscape Engage Cables for M215s, end-fed:  
Microinverters per Branch in Landscape**

	3	6	9	12	15	18	21	24
VRise	0.12	0.32	0.63	1.05	1.58	2.41	2.95	3.78
%	0.06	0.16	0.30	0.51	0.76	1.16	1.42	1.82
Current	1.79	3.58	5.37	7.16	8.95	10.74	12.53	14.32

**Internal VRise within 208 VAC, 5 wire, 1.0m portrait Engage Cables for M215s, center-fed:  
Microinverters per Sub-Branch (Two Balanced Sub-Branches) in Portrait**

	3	6	9	12
VRise	0.08	0.21	0.39	0.65
%	0.04	0.10	0.19	0.31
Current	1.79	3.58	5.37	7.16

**Internal VRise within 208 VAC, 5 wire, 1.7m landscape Engage Cables for M215s, center-fed:  
Microinverters per Sub-Branch (Two Balanced Sub-Branches) in Landscape**

	3	6	9	12
VRise	0.12	0.32	0.63	1.05
%	0.06	0.16	0.30	0.51
Current	1.79	3.58	5.37	7.16

Please see sample calculations on pages 8-11 of this document for detailed use of these tables.

## Engage and Wire Sizing Overview

The Engage Cable is a continuous length of 12 AWG stranded copper, outdoor rated cable, with integrated connectors for M215 Microinverters. The Engage Cable is available either with 1.025 meters between connectors for PV modules in portrait orientation or with 1.7 meters between connectors for PV modules in landscape orientation. In addition, the Engage Cable is available in both 240 V<sub>AC</sub> and 208 V<sub>AC</sub> three-phase configurations.

Voltage type/ conductor count	Connector spacing	PV module orientation
240 V <sub>AC</sub> , 4 conductor	1.025 m (40")	Portrait
240 V <sub>AC</sub> , 4 conductor	1.7 m (67")	Landscape
208 V <sub>AC</sub> , 5 conductor	1.025 m (40")	Portrait
208 V <sub>AC</sub> , 5 conductor	1.7 m (67")	Landscape

In this document, calculations are provided for all Engage Cable options. Regardless of the application, Enphase recommends that the total percentage of voltage rise in the AC wiring be less than 2%, with (an inclusive) less than 1% voltage rise in the Engage Cable. Using the examples in this paper, you will be able to calculate VRise values for your project.

All components within the system wiring can add resistance and must be considered when calculating the total VRise. Typically, the resistance of three distinct wire sections and several wire terminations must be quantified. There is also some resistance associated with each OCPD (Over Current Protection Device), typically a circuit breaker. As all of these resistances are in series, they are cumulative. Since the same current is flowing through each resistance, the total VRise is simply the total current times the total resistance. For a single-phase system, the total resistance is equal to two times the one-way resistance. For a three-phase system, each of the three line currents and resistances must be calculated.

Wire sizing is very important because improper wire size can result in nuisance tripping of the microinverter's utility protective functions. This results in loss of energy harvest. Note also that although the National Electric Code recommends that branch circuit conductors be sized for a maximum of 3% VRise (Article 210.19, FPN 4.), this value is rarely sufficiently conservative for a utility-interactive inverter.

## What Contributes to Voltage Rise

Enphase Microinverter systems are installed as dedicated branch circuits. Each dedicated branch circuit of M215 Microinverters is protected by a 20A OCPD. Wire size, circuit current, circuit length, voltage margin, and utility voltage must be considered.

- **Wire size:** Of course, there is a tradeoff to be made between increased wire size and increased cost. The wire size can often be increased by one AWG trade size with minimal cost impact. At some point, however, increasing the wire size necessitates increases in the conduit and/or terminal size, resulting in increased costs. However, these increases in wiring and conduit costs can be offset by the increase in energy production over the lifetime of the system.
- **Circuit current:** The circuit current will vary depending on which "wire section" is being considered in the installation. See "VRise Calculations by Wire Section". A typical

installation will contain three wire sections. In the Engage Cable (wire section 1), the current increases with each inverter added to the circuit.

- **Circuit length:** There is often little choice in circuit length, but center-feeding the dedicated branch circuit will significantly reduce voltage rise within the branch. See "Advantages of Center-Feeding the AC Branch Circuits" on page 7.
- **Voltage margin:** If the service voltage is chronically high, the utility will sometimes perform a tap change on the distribution transformer. This can provide a percent or two of additional voltage margin.
- **Utility voltage:** The utility strives to maintain voltage at the PCC within +/- 5% of nominal. The protective functions of the microinverters are set to +10%/-12% by default. The high voltage end of the tolerance is of most concern because the inverters are a SOURCE and not a LOAD. If the utility is consistently 5% high, that leaves less than 5% for all wiring and interconnection losses and inverter measurement accuracy. If you are concerned about the utility's voltage, you may request that your utility place a data logger at the PCC and make a record of the voltages available to you at the site.

## VRise Calculations by Wire Section

A typical installation will have three wire sections where voltage rise must be considered:

1. Internal voltage rise within the Engage Cables, from the microinverter to the array-mounted AC junction box.
2. Voltage rise from the array-mounted AC junction box, along the AC branch circuits, to the load center containing the dedicated microinverter OCPDs (circuit breakers).
3. Voltage rise from the load center to the PCC.

We must calculate each component individually and make sure that the total voltage rise is less than 2%. Additional losses will exist at the terminals, connectors, and in circuit breakers; however, if you design for a 2% total voltage rise, these other factors may be ignored. The illustration details the three wire sections where voltage rise must be considered:

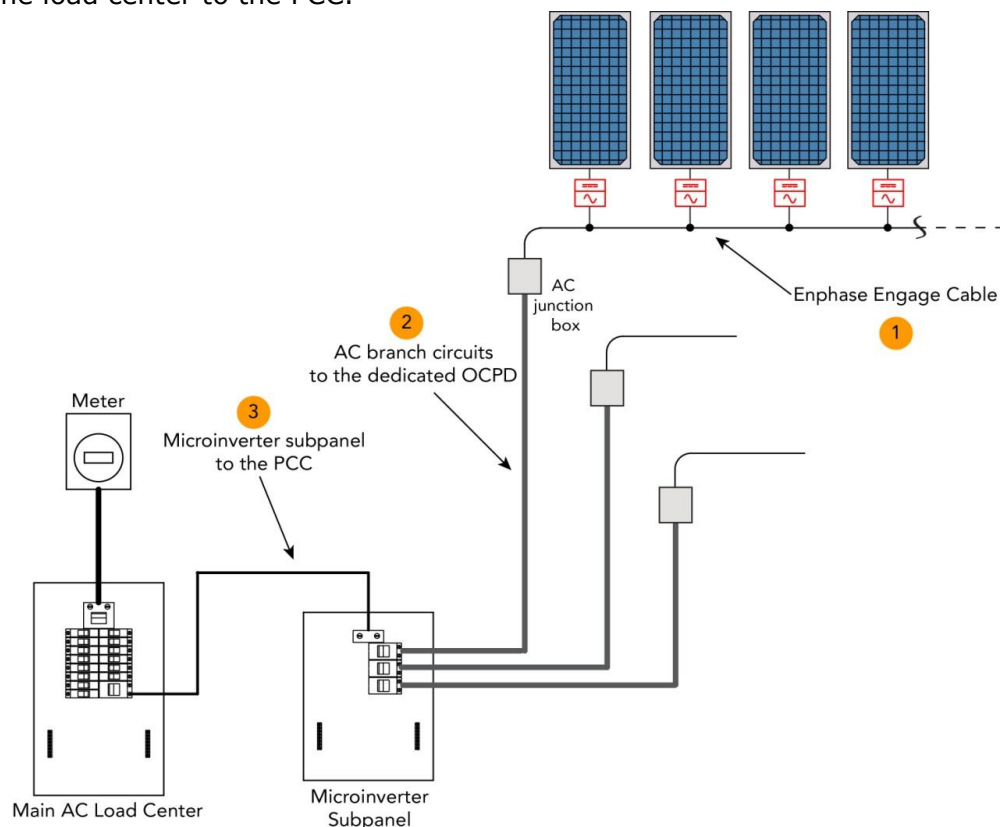

## Internal VRise within the Engage Cable

VRise within the microinverter branch circuit can be easily determined. The following diagram represents a fully populated branch circuit that is end-fed, and it illustrates how the voltages measured at the individual microinverters increase with their position in the branch circuit.

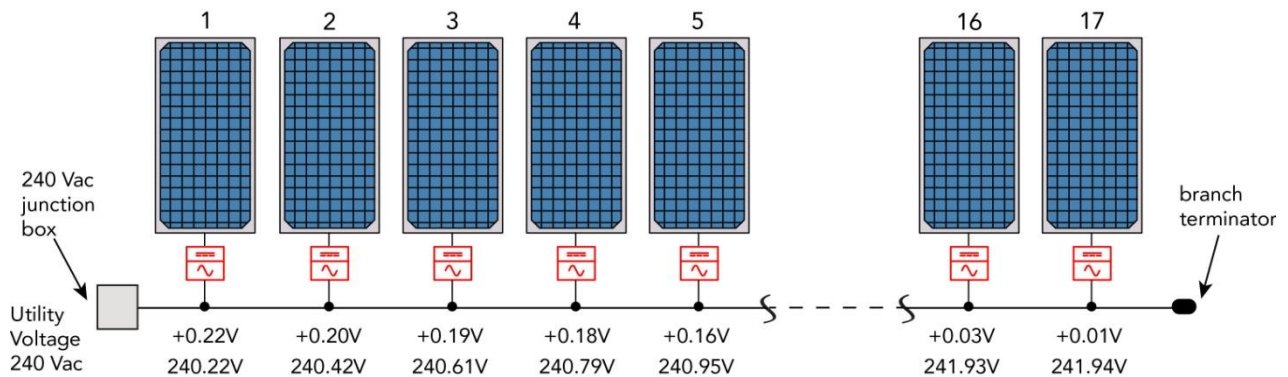

As the number of microinverters in a branch circuit rises, the voltage also rises in a nonlinear manner. In the following graph, the top row of numbers are the incremental voltage rises from one microinverter to the next, and the bottom row are the cumulative line-to-line voltages overall (for a 240 V<sub>AC</sub> system, in this example). This graph illustrates how the number of microinverters connected to a portrait-oriented Engage Cable (with connectors spaced one meter apart) will cause the voltage to rise when operating at 240V<sub>AC</sub>.

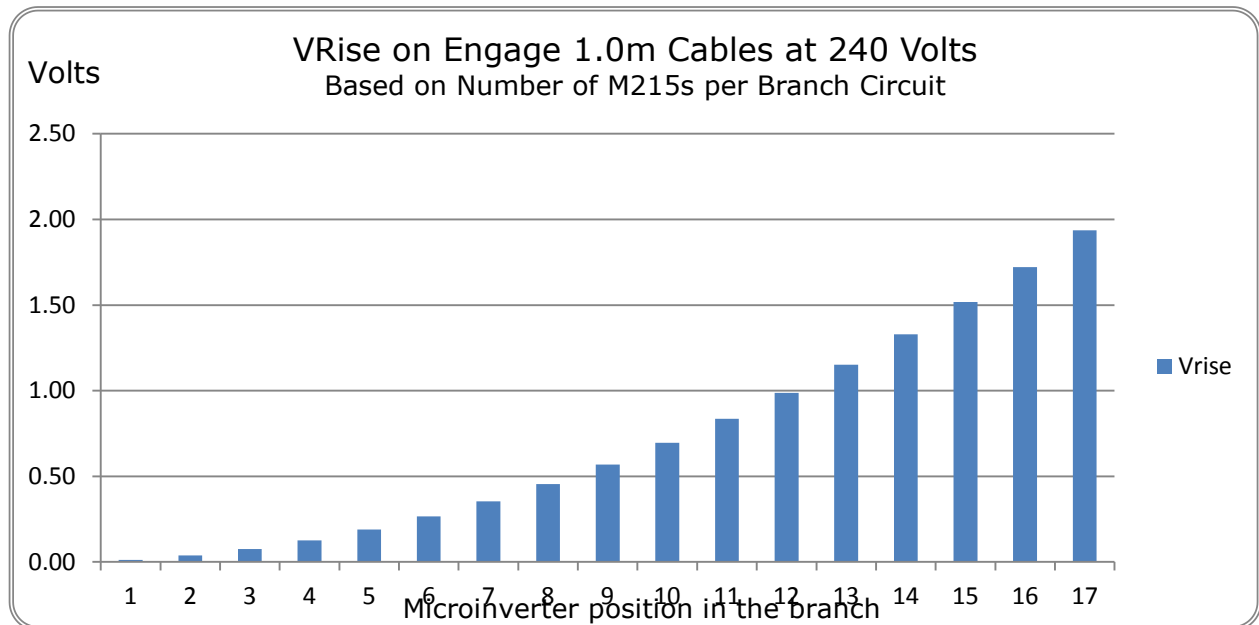

## Advantages of Center-Feeding the AC Branch Circuits

The Engage Cable is both more efficient and less impacted by the effects of VRise than past Enphase cabling systems. This is particularly true of the Engage Cable with connectors spaced one meter apart for portrait applications. However, it is still important to calculate voltage rise for the entire system from the array to the PCC.

Since the voltage rise is nonlinear, reducing the number of microinverters in the branch circuit greatly reduces the voltage measured at the last microinverter in the branch. One way to minimize this voltage rise is to center-feed the branch (i.e., divide the circuit into two sub-branch circuits protected by a single OCPD). The following diagram illustrates the center-fed method.

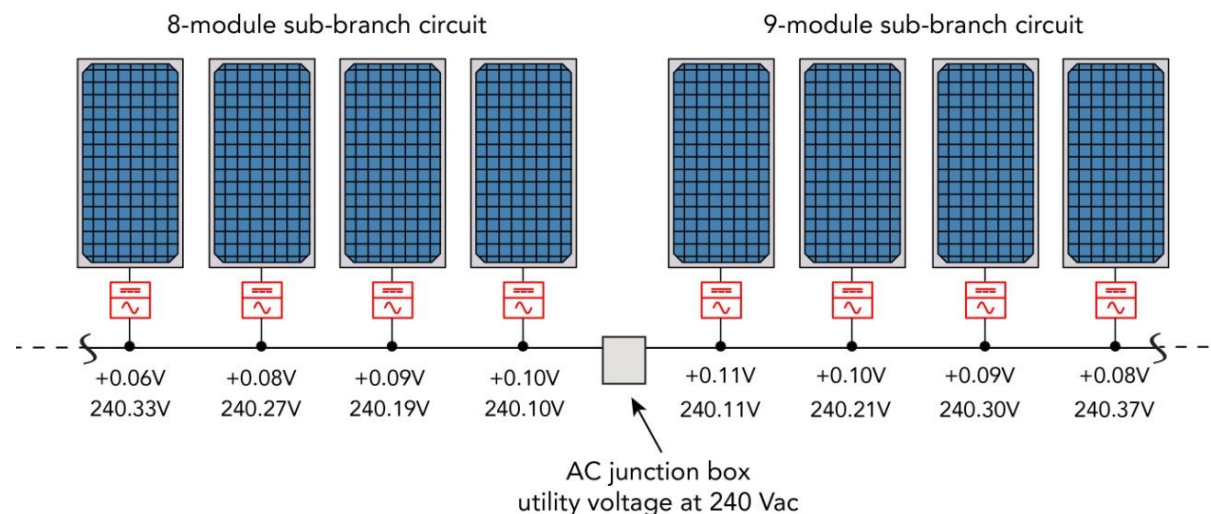

When a branch circuit feeds multiple roofs or sub-arrays, it is common to divide the sub-arrays into sub-branch circuits. It is acceptable to have different numbers of microinverters on each roof or sub-branch circuit. This is because the conductors from each Engage Cable on that branch circuit are paralleled within a junction box where all red conductors come together, all black conductors come together, etc.

A fully populated center-fed branch circuit could still have 17 M215 Microinverters, with nine on one sub-branch circuit and eight on another sub-branch circuit. All microinverters will meet in the same junction box. The longer of the two sub-branch circuits will have nine microinverters. With center-feeding, the last microinverter in the branch circuit will measure a 0.57-volt increase, rather than a 1.94-volt increase when end-fed.

## Calculating Total Voltage Rise for Single-Phase Installations

### Voltage Rise for M215s with the 240 V<sub>AC</sub> Engage Cable

#### Internal VRise within 240 VAC, 4 wire, 1.0m portrait Engage Cables for M215s, end-fed:

Microinverters per Branch in Portrait																	
	1	2	3	4	5	6	7	8	9	10	11	12	13	14	15	16	17
VRise	0.01	0.04	0.08	0.13	0.19	0.27	0.35	0.46	0.57	0.70	0.84	0.99	1.15	1.33	1.52	1.72	1.94
%	0.01	0.02	0.03	0.05	0.08	0.11	0.15	0.19	0.24	0.29	0.35	0.41	0.48	0.55	0.63	0.72	0.81
Current	0.90	1.79	2.69	3.58	4.48	5.38	6.27	7.17	8.06	8.96	9.85	10.75	11.65	12.54	13.44	14.33	15.23

#### Internal VRise within 240 VAC, 4 wire, 1.7m landscape Engage Cables for M215s, end-fed:

Microinverters per Branch in Landscape																	
	1	2	3	4	5	6	7	8	9	10	11	12	13	14	15	16	17
VRise	0.02	0.06	0.13	0.21	0.31	0.44	0.59	0.75	0.94	1.15	1.38	1.64	1.91	2.20	2.52	2.85	3.21
%	0.01	0.03	0.05	0.09	0.13	0.18	0.24	0.31	0.39	0.48	0.58	0.68	0.80	0.92	1.05	1.19	1.34
Current	0.90	1.79	2.69	3.58	4.48	5.38	6.27	7.17	8.06	8.96	9.85	10.75	11.65	12.54	13.44	14.33	15.23

#### Internal VRise within 240 VAC, 4 wire, 1.0m portrait Engage Cables for M215s, center-fed:

Microinverters per Sub-Branch (Two Sub-Branches) in Portrait																	
	1	2	3	4	5	6	7	8	9								
VRise	0.01	0.04	0.08	0.13	0.19	0.27	0.35	0.46	0.57								
%	0.01	0.02	0.03	0.05	0.08	0.11	0.15	0.19	0.24								
Current	0.90	1.79	2.69	3.58	4.48	5.38	6.27	7.17	8.06								

#### Internal VRise within 240 VAC, 4 wire, 1.7m landscape Engage Cables for M215s, center-fed:

Microinverters per Sub-Branch (Two Sub-Branches) in Landscape																	
	1	2	3	4	5	6	7	8	9								
VRise	0.02	0.06	0.13	0.21	0.31	0.44	0.59	0.75	0.94								
%	0.01	0.03	0.05	0.09	0.13	0.18	0.24	0.31	0.39								
Current	0.90	1.79	2.69	3.58	4.48	5.38	6.27	7.17	8.06								

### Sample Calculation

As part of this analysis, we will run the calculations for a sample scenario. The sample scenario will involve calculating the total VRise of 51 M215 Microinverters in portrait orientation with three branch circuits of 17 M215 Microinverters. Each branch circuit will be center-fed and separated into two sub-branch circuits of eight and nine microinverters. Use the Portrait Table above to evaluate a sub-branch circuit of nine M215s.

**\*The voltage rise on the 240 V<sub>AC</sub> Engage Cable for nine M215s in portrait is 0.24%.**

### **Voltage Rise from the Array-Located Junction Box to the Microinverter Subpanel**

Calculating the voltage rise in this portion of the circuit is determined by multiplying the combined current of the microinverters in the branch by the total resistance of the wire run.

$$VRise = (\text{amps/inverter} * \# \text{ of inverters}) * (\text{resistance } \Omega/\text{ft}) * (2 \text{ way wire length})$$

The following example is for a fully populated branch circuit of 17 M215 Microinverters.

M215 full load AC current = 0.9 amps (0.8958 amps)

Wire gauge for individual branch circuit = #10 AWG THWN-2 CU

#10 AWG THWN-2 CU resistance = 0.00129/ft (from NEC 2008, Chapter 9, Table 8)

Length of individual branch circuit = 40 feet

Two way wire length= 80 feet

$$\begin{aligned} VRise &= (0.9 \text{ amps} * 17) * (0.00129 \Omega/\text{ft}) * (40' * 2) \\ &= 15.3 * 0.00129 * 80' \\ &= \mathbf{1.58 \text{ volts}} \\ &= 1.58 \text{ volts}/240 \text{ volts} = \mathbf{0.66\% VRise} \end{aligned}$$

**\*The voltage rise from the junction box to the microinverter subpanel is 0.66%.**

### **Voltage Rise from the Microinverter Subpanel to the PCC**

Calculating the VRise in this portion of the circuit is determined by multiplying the combined current of all the microinverters in the array by the total resistance of the wire run.

The following example is for three fully populated branch circuits of 17 M215 Microinverters

$$VRise = (\text{amps/inverter} * \# \text{ of inverters}) * (\text{resistance } \Omega/\text{ft}) * (2 \text{ way wire length})$$

each (51 units total).

Current of 17 M215 = 15.3 amps (15.2286 amps)

Current of 3 branch circuits of 17 M215 = 45.9 amps

Wire gauge for the microinverter subpanel feed = #4 AWG THWN-2 CU

#4 AWG THWN-2 CU resistance = 0.000321/ft (from NEC Chapter 9, Table 8)

Length of the microinverter subpanel feed = 80 feet

Two way wire length= 160 feet

$$\begin{aligned} VRise &= (45.9 \text{ amps}) * (0.000321 \Omega/\text{ft}) * (80' * 2) \\ &= 45.9 * 0.000321 * 160' \\ &= \mathbf{2.36 \text{ volts}} \\ &= 2.36 \text{ volts}/240 \text{ volts} = \mathbf{0.99\% VRise} \end{aligned}$$

**\*The voltage rise from the microinverter subpanel to the main service meter is 0.99%.**

## Summary of Calculations for 240 V<sub>AC</sub> Applications

With the utility operating at the upper limit of their allowable tolerance (+5%) and the microinverters having a measurement accuracy of 2.5%, we are left with a voltage rise budget of 5.4 volts (2.25%) for all wiring to the PCC. The calculated VRise for all three portions of the system must be 5.4 volts or less. For systems with very long branch circuit runs and/or very long runs from the PV load center to the PCC, it is best to make the VRise in the Engage Cable as small as possible. As we have already determined, 5.4 volts is equal to 2.25% of the nominal voltage. After accounting for additional losses within connections, terminals, circuit breakers, and unexpected increases in wire length, we recommend implementation of a total system voltage rise of less than 2%.

Voltage rise from the microinverters to the AC junction box	= 0.24%
Voltage rise from the AC junction box to the microinverter subpanel	= 0.66%
<u>Voltage rise from the microinverter subpanel to the main service panel (PCC)</u>	<u>= 0.99%</u>
Total system voltage rise for all three wiring sections	= 1.89%

With proper wire sizing, we can limit the total voltage rise on all of the wire sections to less than 2%. However, if we had not separated each of the 17 module branch circuits into two sub-branch circuits, the voltage rise would be too high, and our system would suffer from an AC Voltage Out Of Range (ACVOOR) condition. This example shows that center feeding is a great way to decrease costs, improve production, and increase system reliability.

## Calculating Total Voltage Rise for Three-Phase Installations

### Voltage Rise for M215s with the 208 V<sub>AC</sub> Engage Cable

#### Internal VRise within 208 VAC, 5 wire, 1.0m portrait Engage Cables for M215s, end-fed:

	Microinverters per Branch in Portrait								
	3	6	9	12	15	18	21	24	
VRise	0.08	0.21	0.39	0.65	0.96	1.35	1.79	2.30	
%	0.04	0.10	0.19	0.31	0.46	0.65	0.86	1.11	
Current	1.79	3.58	5.37	7.16	8.95	10.74	12.53	14.32	

#### Internal VRise within 208 VAC, 5 wire, 1.7m landscape Engage Cables for M215s, end-fed:

	Microinverters per Branch in Landscape								
	3	6	9	12	15	18	21	24	
VRise	0.12	0.32	0.63	1.05	1.58	2.41	2.95	3.78	
%	0.06	0.16	0.30	0.51	0.76	1.16	1.42	1.82	
Current	1.79	3.58	5.37	7.16	8.95	10.74	12.53	14.32	

#### Internal VRise within 208 VAC, 5 wire, 1.0m portrait Engage Cables for M215s, center-fed:

	Microinverters per Sub-Branch (Two Balanced Sub-Branches) in Portrait								
	3	6	9	12					
VRise	0.08	0.21	0.39	0.65					
%	0.04	0.10	0.19	0.31					
Current	1.79	3.58	5.37	7.16					

**Internal VRise within 208 VAC, 5 wire, 1.7m landscape Engage Cables for M215s, center-fed: Microinverters per Sub-Branch (Two Balanced Sub-Branches) in Landscape**

	3	6	9	12				
VRise	0.12	0.32	0.63	1.05				
%	0.06	0.16	0.30	0.51				
Current	1.79	3.58	5.37	7.16				

**Sample Calculation:**

For this example, we'll consider the voltage rise calculations for a system using 72 M215 Microinverters with 208 V<sub>AC</sub> three-phase service. The system will have three fully-populated branch circuits of 24 M215 Microinverters mounted in portrait orientation. For fully loaded branch circuits with 208 V<sub>AC</sub>, we recommend that the circuit is center-fed to minimize voltage rise. The M215 Microinverter produces power on two legs, and the phases are balanced by the physical internal rotation of the phase cables inside the Engage Cable. A center-fed branch of 24 microinverters would have 12 microinverters on one sub-branch circuit and 12 microinverters on the other.

**\*The voltage rise for a branch circuit of 24 M215s center-fed, with two sub-branch circuits of 12 microinverters each in portrait is 0.31%.**

**Voltage Rise from the Array-Located Junction Box to the Microinverter Subpanel**

Calculating the VRise in this portion of the circuit is determined by multiplying the branch circuit output power in watts by the total resistance of the wire run divided by the voltage.

$$\text{VRise} = \frac{(\text{Watts/inverter}) * (\# \text{ of inverters/branch circuit}) * (\Omega/\text{ft}) * (1 \text{ way wire length})}{208 \text{ volts}}$$

The following example is for a fully populated branch circuit of 25 M215 Microinverters.

- M215 output in watts = 215 watts
- # of microinverters per branch circuit= 24
- Wire gauge for individual branch circuit = #10 AWG THWN-2 CU
- #10 AWG THWN-2 CU resistance = 0.00129 Ω/ft (from NEC Chapter 9, Table 8)
- Length of individual branch circuit = 40 feet

$$\begin{aligned} \text{VRise} &= (215 \text{ watts}) * (24) * (0.00129 \Omega/\text{ft}) * (40') / 208 \text{ volts} \\ &= 5,160 \text{ watts} * .0516 \Omega / 208 \text{ volts} \\ &= \mathbf{1.28 \text{ volts}} \\ &= 1.28 \text{ volts}/208 \text{ volts} = \mathbf{0.62\% \text{ VRise}} \end{aligned}$$

**\*The voltage rise from the junction box to the microinverter subpanel is 0.62%.**

**Voltage Rise from the Microinverter Subpanel to the Main Service Meter (PCC)**

Calculating the VRise in this portion of the circuit is determined by multiplying the total microinverter subpanel output power in watts by the total resistance of the wire run divided by the voltage. The phases are balanced by the physical internal rotation of the phases inside the Engage Cable.

$$\text{VRise} = \frac{(\text{Watts/inverter}) * (\# \text{ of inverters/Microinverter subpanel}) * (\Omega/\text{ft}) * (1 \text{ way wire length})}{208 \text{ volts}}$$

The following calculations are for three fully populated branch circuits of 24 M215 Microinverters, with two sub-branch circuits of 12 microinverters each, in portrait, for a total of 72 microinverters.

M215 output in watts = 215 watts  
 # of Microinverters per microinverter subpanel = 72  
 Wire gauge for the microinverter subpanel feed = #2 AWG THWN-2 CU  
 #2 AWG THWN-2 CU resistance = 0.000201  $\Omega$ /ft (from NEC Chapter 9, Table 8)  
 Length of microinverter subpanel feed = 80 feet

$$\begin{aligned} \text{VRise} &= (215 \text{ watts}) * (72) * (.000201 \text{ } \Omega/\text{ft}) * (80') / 208 \text{ volts} \\ &= 15,480 \text{ watts} * 0.01608 \text{ } \Omega / 208\text{volts} \\ &= \mathbf{1.20 \text{ volts}} \\ &= 1.20 \text{ volts}/208 \text{ volts} = \mathbf{0.58\% \text{ VRise}} \end{aligned}$$

**\*The voltage rise from the microinverter subpanel to the main service meter is 0.58%.**

### Summary of Calculations for 208 V<sub>AC</sub> Applications

With the utility operating at the upper limit of their allowable tolerance (+5%) and the microinverters having a measurement accuracy of 2.5%, we are left with a voltage rise budget of 4.88 volts (2.25%) for all wiring to the PCC. The calculated VRise for all three portions of the system must be 4.88 volts or less. For systems with long branch circuit runs and/or long runs from the inverter subpanel to the main service panel or PCC, it is best to make the VRise in the Engage Cable as small as possible. However, after accounting for additional losses within connections, terminals, circuit breakers, and unexpected increases in wire length, we recommend calculating the total system voltage rise to be less than 2%.

Voltage rise from the microinverters to the AC junction box	= 0.50%
Voltage rise from the AC junction box to the microinverter subpanel	= 0.62%
<u>Voltage rise from the microinverter subpanel to the main service meter (PCC)</u>	<u>= 0.58%</u>
Total system voltage rise for all three wiring sections	= 1.70%

In this example, we were able keep the VRise to less than 2%. Note that this would have been impossible without center-feeding the circuit to create two sub-branch circuits at the array. To reiterate, center feeding is a great way to decrease costs, improve production, and increase system reliability.

### Conclusion

Center-feeding each branch circuit in an Enphase Microinverter system is essential, both for optimal microinverter operation and to minimize wire costs for the installer. Following the guidelines and calculations in this document will help to minimize any voltage rise or voltage drop issues with your installation.