

MANUFACTURERS DECLARATION

Enphase Energy NL
Het Zuiderkruis 65
5215 MV 's-Hertogenbosch
Nederland

declare under our sole responsibility that the product identified as:

Energy Storage System

Model number: B03-T01-INT00-1-2

SKU numbers: ENCHARGE-3T-1P-INT (consists of 1 x B03-T01-INT-1-2)
and
ENCHARGE-10T-1P-INT (consists of 3 x B03-T01-INT-1-2)

to which this declaration relates is in conformity with the feed-in limitation at the grid connection point:

As outlined in the FNN document "Connection and operation of storage systems on the low-voltage network", the Enphase system has been tested and it has been confirmed that the above listed components meet the requirements:

4.10 Storage without delivery to the public network. Power from the public network is not used for charging and power is not feed into the public network from the battery storage.

4.11 To prevent the feed in, the energy flow at the grid connection point is measured by Envoy-S gateway (ENV-S-WM-230) which controls the Encharge system.

An example of an installation of Energy Storage System in three phase system is shown below. For more examples, refer to the Quick Install Guide (Rev 04-09-30-2021).

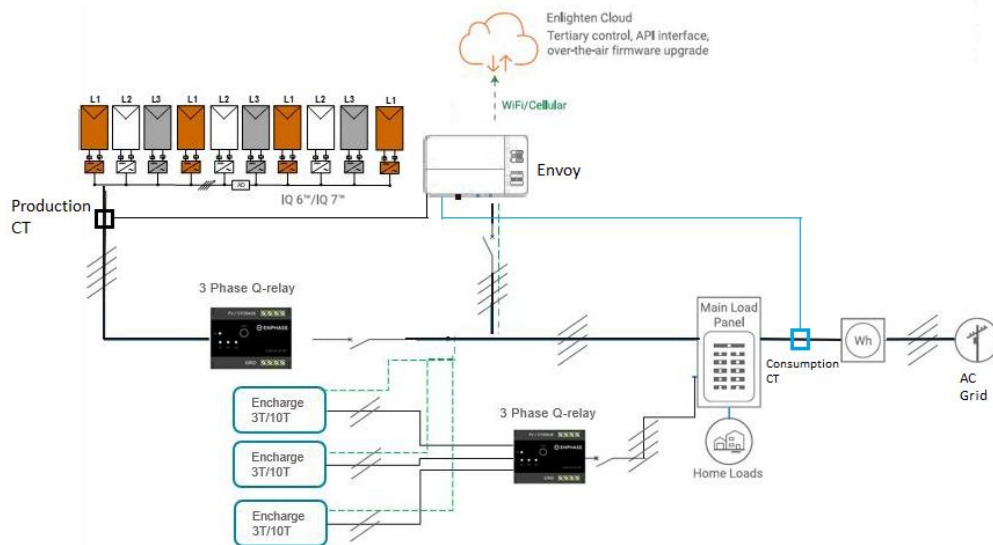

Signed on behalf of Enphase Energy, Inc.

06 October 2021
Christchurch, New Zealand



Daniel Keis
Staff Engineer, Automation & Test