

CLIPPERCREEK

A division of Enphase Energy, Inc.



User Manual



Model PCS



PLEASE NOTE

This user's manual includes the latest information at the time of printing. Enphase Energy, Inc. reserves the right to make changes to this product without further notice. Changes or modifications to this product by other than an authorized service facility may void the product warranty.

If you have questions about the use of this product, contact your customer service representative. Refer to the Customer Support section located in this guide.



WARNING: This product can expose you to chemicals, including Carbon Black, which is known to the State of California to cause cancer. For more information go to: www.P65Warnings.ca.gov



AVERTISSEMENT: Ce produit peut vous exposer à des agents chimiques, y compris Noir Carbone, identifiés par l'État de Californie comme pouvant causer le cancer. Pour de plus amples informations, prière de consulter: www.P65Warnings.ca.gov



ADVERTENCIA: Este producto puede exponerte a químicos, incluso Negro Carbón, que se conocido por el Estado de California como causante de cáncer. Para más información visite: www.P65Warnings.ca.gov

To download or view the latest version of this manual please visit <https://www.clippercreek.com/installation-manuals>

CONTENTS

IMPORTANT SAFETY INSTRUCTIONS	5
Instructions Pertaining to a Risk of Fire or Electric Shock	7
Additional Safety Information	12
FCC INFORMATION.....	15
OPERATION.....	16
The PCS Front Panel.....	17
GROUNDING INSTRUCTIONS.....	18
MOVING & STORAGE INSTRUCTIONS	19
MAINTENANCE	20
MOUNTING THE SAE J1772 CONNECTOR HOLSTER	22
CHARGE CABLE WRAP GUIDELINES.....	24
USING THE PADLOCK.....	25
CUSTOMER SUPPORT	27
SPECIFICATIONS.....	28
WARRANTY INFORMATION	29

ILLUSTRATIONS

FIGURES

1. Front Panel	17
2. Mounting the Holster Using the Exterior Wood Screws and Washers.....	23
3. Drape the Charge Cable Loosely Around the PCS Enclosure.....	24
4. Locking the SAE J1772 Connector with Padlock Included.....	25
5. Charge Connector Secured with Padlock which Cannot be Removed from Vehicle without Key	26
6. Padlock Used in Combination with Connector Holster After Charging.....	26

TABLES

1. Front Panel LED Information	17
--------------------------------------	----

IMPORTANT SAFETY INSTRUCTIONS

ClipperCreek Electric Vehicle Supply Equipment (EVSE) is designed with the safety concerns of the end user as an utmost priority; however, the following safety precautions must be read and followed:

- The EVSE and electrical wiring should be installed by a qualified electrician in accordance with local electrical codes and ordinances.
- Grounding Instructions - The EVSE should be connected to a grounded, metal, permanent wiring system; or an equipment-grounding conductor should be run with circuit conductors and connected to a grounding terminal or lead on the EVSE. Connections to the EVSE should comply with all local electrical codes and ordinances.
- Call the local service provider anytime a procedural question arises; **DO NOT** attempt to perform a procedure you are unsure of.
- Read all installation instructions carefully before installing and operating the EVSE.

The following symbols may be found in this manual or on labels affixed to the charge station:

NOTE: *This means pay particular attention.* Notes contain helpful suggestions.

REMARQUE: *Cela signifie accorder une attention particulière.* Les remarques contiennent des suggestions utiles.

NOTA: *Esto significa que debe prestar especial atención.* Las notas contienen sugerencias útiles.



CAUTION: *This symbol means be careful.* You are capable of doing something that might result in damage to the equipment.

ATTENTION: *Ce symbole signifie être prudent.* Vous êtes capable de faire quelque chose qui pourrait causer des dommages à l'équipement.

ATENCIÓN: Este símbolo significa tener cuidado. Usted es capaz de hacer algo que puede resultar en daños al equipo.



WARNING: *This symbol means danger.* You are in a situation that could cause bodily injury. Before you work on any electrical equipment, be aware of the hazards involved with electrical circuitry and standard practices for preventing accidents.

AVERTISSEMENT: *Ce symbole signifie danger.* Vous êtes dans une situation qui pourrait causer des blessures corporelles. Avant de travailler sur un équipement électrique, être conscient des dangers présentés par les circuits électriques et les pratiques courantes de prévention des accidents.

ATENCIÓN: Este símbolo significa tener cuidado. Usted es capaz de hacer algo que puede resultar en daños al equipo.

Instructions Pertaining to a Risk of Fire or Electric Shock

When using the PCS, basic electrical safety precautions should be followed:

- Use this EVSE to charge electric vehicles equipped with an *SAE J1772 charge port only*. Consult the vehicle's owner manual to determine if the vehicle is equipped with the correct charge port.
- Make certain the EVSE SAE J1772 charge cable is positioned so it will not be stepped on, tripped over, or otherwise subjected to damage or stress.
- This product contains no user serviceable parts. Consult the Customer Support section in this manual for service information. Do not attempt to repair or service the EVSE yourself.
- Do not operate your EVSE if it or the SAE J1772 charge cable is physically open, cracked, frayed, or otherwise visibly damaged. Contact a Service Representative for service immediately. Consult the Customer Support section in this manual for information on the Service Representative in your area.
- Not for use in commercial garages where a COMMERCIAL GARAGE is defined as a facility (or portion thereof) used for the repair of internal combustion vehicles in which the area may be classified due to flammable vapors being present (such as from gasoline).
- Do not place fingers inside of the coupler end of the SAE J1772 charge cable.
- Do not allow children to operate this device. Adult supervision is mandatory when children are in proximity to an EVSE that is in use.
- A dedicated NEMA outlet is **highly recommended**. NEMA outlets wear out over time particularly when repeated insertion and removal of NEMA plugs occur. Check the inlet to be sure it is not worn. A worn outlet can cause the plug

connection to overheat and become a fire hazard. Do not use a plug that gets excessively hot. It is recommended that plug-in EVSE remain plugged in.

- Have an electrician verify all wiring to the outlet is correct and in compliance with local code requirements before connecting the EVSE.
- **Do Not** use this EVSE with an extension cord or wall plug adapter. Plug this EVSE directly into the outlet.
- Ensure that the EVSE is mounted to the wall or placed on a support so it does not hang from the outlet. Outlets are not designed to support the weight of the EVSE.
- Installing a dedicated hospital grade outlet is recommended if the PCS will be used on a regular basis. Hospital grade outlets are more robust than standard 120V outlets and are designed for use with high capacity 120V appliances like the PCS.

Instructions se Rapportant à un Risque d'Incendie ou de Choc Électrique

Lorsque l'utilisation de la PCS, précautions fondamentale de sécurité électrique doivent être suivies:

- Utilisez cette station de recharge pour charger les véhicules électriques équipés d'un *SAE J1772 port de recharge seulement*. Consultez le manuel du propriétaire du véhicule afin de déterminer si le véhicule est équipé d'un correcte port de recharge.
- Assurez-vous que le SAE J1772 câble de recharge sur la station de recharge est positionné de telle sorte qu'il ne sera pas piétiné, accroché plus de, ou autrement endommagé ou de subir le stress.
- Ce produit ne contient aucune pièce réparable par l'utilisateur. Consultez la section Support à la Clientèle dans ce manuel pour obtenir des informations de service. N'essayez pas de

réparer ou d'entretenir la station de recharge vous-même.

- Ne faites pas fonctionner votre station ou le câble de recharge si elles sont physiquement ouverte, fissuré, effiloché, ou autrement visiblement endommagé. Contactez votre représentant du service pour service immédiatement. Consultez la section Support à la clientèle dans ce manuel pour obtenir des informations sur le représentant du service dans votre région.
- Ne pas utiliser dans les garages commerciaux où un garage commercial est défini comme une installation (ou une partie) utilisé pour la réparation de véhicules à combustion interne dans lequel la zone peut être classée en raison de vapeurs inflammables étant présents (Tels que de l'essence.)
- Ne posez pas les doigts à l'intérieur de l'extrémité du SAE J1772 coupleur du câble de recharge.
- Ne pas laisser les enfants utiliser cet appareil. Supervision d'un adulte est obligatoire lorsque des enfants sont à proximité d'une station de recharge qui est en cours d'utilisation.
- Une sortie NEMA dédiée est **fortement recommandée**. Les sorties NEMA s'usent avec le temps, en particulier lorsque l'insertion et le retrait des prises NEMA sont répétés. Vérifiez l'entrée pour vous assurer qu'elle n'est pas usée. Une sortie usée peut provoquer une surchauffe du connecteur de raccordement et constituer un risque d'incendie. Ne pas utiliser de prise qui deviendrait excessivement chaude. Il est recommandé que la prise de l'EVSE reste branchée.
- Faites vérifier par un électricien que tout le câblage de l'appareil soit correctement effectué et conforme aux exigences de la réglementation locale avant de raccorder l'EVSE.
- Ne Pas utiliser cet EVSE avec une rallonge ou adaptateur de prise murale. Branchez cet EVSE directement dans la prise.
- S'assurer que l'EVSE est fixé au mur ou placé sur un support afin qu'il ne soit pas suspendu à l'installation électrique.

Cette dernière n'est pas conçue pour supporter le poids de l'EVSE.

- L'installation d'une prise de qualité similaire à celles des hôpitaux est recommandée si le PCS doit être utilisé régulièrement. Les prises dans les hôpitaux sont plus robustes que les prises standard de 120 V et sont conçues pour être utilisées avec des appareils de 120 V de grande capacité comme le PCS.

Instrucciones sobre Riesgo de Incendio o Descarga Eléctrica

Al utilizar el PCS, se deben seguir las siguientes precauciones básicas de seguridad eléctrica:

- Utilice este EVSE para cargar vehículos eléctricos equipados con un *puerto de carga SAE J1772 únicamente*. Consulte el manual del propietario del vehículo para determinar si el vehículo está equipado con el puerto de carga correcto.
- Asegúrese de que el cable de carga del EVSE SAE J1772 esté colocado de manera que no sea pisado, ni cause tropezos, ni se someta a daños o tensiones.
- Este producto no contiene partes reparables por el usuario. Consulte la sección de Atención al Cliente en este manual para obtener información de servicio. No intente reparar o reparar el EVSE usted mismo.
- No opere su EVSE si éste o el cable de carga SAE J1772 están físicamente abiertos, agrietados, deshilachados o dañados de otra manera. Póngase en contacto con un Representante de Servicio Técnico para su reparación. Consulte la sección de Atención al Cliente en este manual para obtener información sobre el Representante de Servicio Técnico en su área.
- Este dispositivo no es para uso en garajes comerciales, en el que un GARAJE COMERCIAL se define como

una instalación (o parte de la misma) utilizada para la reparación de vehículos de combustión interna, en los que el área puede ser clasificada debido a la presencia de vapores inflamables (como los de la gasolina).

- No coloque los dedos dentro del extremo del acoplador del cable de carga SAE J1772.
- No permita que los niños operen este dispositivo. La supervisión de un adulto es obligatoria cuando haya niños que estén cerca de un EVSE que está en uso.
- Se **recomienda encarecidamente** una salida NEMA dedicada. Las tomas NEMA se desgastan con el tiempo, especialmente cuando se produce una conexión y desconexión repetidas de los enchufes NEMA. Verifique la entrada para asegurarse de que no esté desgastada. Un tomacorriente desgastado puede causar que la conexión del enchufe se sobrecaliente y sea riesgo de incendio. No use un enchufe que se caliente demasiado. Se recomienda que el EVSE enchufable permanezca enchufado.
- Haga que un electricista verifique que todo el cableado del tomacorriente sea correcto y que cumpla con los requisitos del código local antes de conectar el EVSE.
- **No Use** este EVSE con un cable de extensión o adaptador de enchufe de pared. Conecte este EVSE directamente a la toma de corriente.
- Asegúrese de que el EVSE esté montado en la pared o colocado sobre un soporte para que no cuelgue del tomacorriente. Los enchufes no están diseñados para soportar el peso del EVSE.
- Se recomienda instalar un tomacorriente de grado hospitalario exclusivo, si el PCS se usará regularmente. Los tomacorrientes de grado hospitalario son más robustos que los tomacorrientes estándar de 120V y están diseñados para usarse con electrodomésticos de alta capacidad de 120V como PCS.

Additional Safety Information



WARNING: Turn off power to the EVSE at the circuit breaker panel before moving, servicing or cleaning the unit.

AVERTISSEMENT: Couper l'alimentation de l'EVSE au niveau du panneau de disjoncteurs avant de déplacer, d'effectuer la maintenance ou de nettoyer l'appareil.

ADVERTENCIA: Desconecte la alimentación del EVSE en el panel del interruptor automático antes de mover, reparar o limpiar la unidad.



WARNING: Always turn off input power to the EVSE at the circuit breaker panel prior to plugging into or unplugging from a wall socket.

AVERTISSEMENT: Toujours éteindre la puissance d'entrée du EVSE sur le panneau du disjoncteur avant de brancher ou de débrancher un socket mur.

ADVERTENCIA: Apague siempre la alimentación de entrada al EVSE en el panel del interruptor de circuito, antes de enchufarlo o desenchufarlo de un tomacorriente.

NOTE: VENTILATION - Some electric vehicles require an external ventilation system to prevent the accumulation of hazardous or explosive gases when charging indoors. Consult the vehicle owner's manual to determine if your vehicle requires ventilation during indoor charging.

REMARQUE: VENTILATION - Certains véhicules électriques nécessitent un système de ventilation externe pour éviter l'accumulation de gaz explosifs ou dangereux lors de la charge à l'intérieur. Consultez le manuel du propriétaire du véhicule pour déterminer si votre véhicule nécessite une ventilation quand le recharge en salle.

NOTA: VENTILACIÓN - Algunos vehículos eléctricos requieren un sistema de ventilación externo para evitar la acumulación de gases peligrosos o explosivos, al ser cargados en interiores. Consulte el manual del propietario del vehículo para determinar si su vehículo requiere ventilación durante la carga en interiores.

NOTE: Vehicles which conform to the SAE J1772 standard for communication can inform the charge station that they require an exhaust fan. The PCS is not equipped to control ventilation fans. Do not charge the vehicle with the PCS if ventilation is required.

REMARQUE: Véhicules qui sont conformes à la norme SAE J1772 de communication peuvent informer la station de recharge qu'ils nécessitent un ventilateur d'extraction. Le PCS n'est pas équipé pour contrôler les ventilateurs. Ne chargez pas le véhicule avec les PCS si la ventilation est nécessaire.

NOTA: Los vehículos que cumplan con el estándar de comunicación SAE J1772 pueden informar que su EVSE requieren un extractor de aire. El PCS no está equipado para controlar ventiladores. No cargue el vehículo con el PCS si se requiere ventilación.



CAUTION: DO NOT CHARGE a vehicle indoors if it requires ventilation. Contact a Service Representative for information.

ATTENTION: NE PAS RECHARGER un véhicule à l'intérieur si il nécessite une ventilation. Contactez votre représentant de service pour plus d'informations.

ATENCIÓN: NO RECARGUE un vehículo en interiores si requiere ventilación. Póngase en contacto con su Representante de Servicio Técnico para obtener más información.

Save these instructions for future reference.

Conservez ces instructions pour référence future.

Guarde estas instrucciones para referencias futuras.

FCC INFORMATION

This device complies with Part 15 of the FCC rules. Operation is subject to the following two conditions: (1) This device may not cause harmful interference, and (2) This device must accept any interference received, including interference that may cause undesired operation.

This product has been designed to protect against Radio Frequency Interference (RFI). However, there are some instances where high powered radio signals or nearby RF-producing equipment (such as digital phones, RF communications equipment, etc.) could affect operation.

If interference to your charge station is suspected, we suggest the following steps be taken before consulting your ClipperCreek Sales and Service Representative for assistance:

1. Reorient or relocate nearby electrical appliances or equipment during charging.
2. Turn off nearby electrical appliances or equipment during charging.



CAUTION: Changes or modifications to this product by other than an authorized service facility may void FCC compliance.

ATTENTION: Modifications apportées à ce produit par quiconque autre qu'un centre de service autorisé peut annuler la conformité FCC.

ATENCIÓN: Cambios o modificaciones a este product por otros que no sean un centro de servicio autorizado pueden anular el cumplimiento con la FCC.

OPERATION

The PCS EVSE is a compact portable EVSE (Electric Vehicle Supply Equipment) that provides the Plug-in Hybrid or Battery Electric Vehicle (together Plug-In Electric Vehicles, or “PEV”) user with a safe and manageable link between the power grid and the PEV.

The PCS is very easy to use. Simply unwrap the SAE J1772 charge cable, plug the wall plug into any grounded 120V dedicated outlet, and plug the charge coupler firmly into the vehicle’s charge port.

Always plug the PCS into the wall socket first.

Normally, the vehicle will immediately request a charge using a special communication line in the cable. Within a few seconds the green “Charging” light on the face of the PCS will turn on and the charging cycle will begin. After an average driving day the vehicle battery pack will require several hours to recharge completely. Charging overnight is the most convenient way to maintain healthy batteries and ensure the vehicle’s full range will be available for the next day.

When the vehicle has stopped charging the green “Charging” light on the PCS will turn off. When disconnecting the PCS, always remove the vehicle connector first, then remove the plug from the wall socket. To remove the vehicle connector once a charge cycle has completed (or to interrupt a charge in progress) press and hold down the latch release lever on the charge coupler handle then unplug the charge coupler from the vehicle charge port. When not in use, the cord may be re-wrapped around the PCS and the entire assembly secured with the included nylon straps.

If charging always takes place in the same location, such as the home garage at night, the PCS may be left plugged into the wall socket without damage.

If the EVSE will be moved often, it is recommended that a hospital grade outlet is used as they are more robust.

***THIS DEVICE IS NOT INTENDED FOR USE WITH AN
EXTENSION CORD.***

The PCS Front Panel

The front panel on the PCS has four indicator lights:

POWER (Amber), indicates that power is available to the PCS.

CHARGING (Green), indicates that the vehicle is requesting a charge and AC power is currently applied to the vehicle.

POWER FAULT (Red), indicates that the PCS is not wired correctly. The problem can be due to improper grounding or a missing Earth Ground. The wiring should be examined by a qualified electrician.

CHARGING FAULT (Red), indicates that the PCS is unable to communicate with the vehicle correctly, or a safety fault condition has been detected by the unit.

Figure 1: Front Panel



Table 1: Front Panel LED Information

#	Amber Power LED	Green Charging LED	Red Power Fault LED	Red Charging Fault LED	Fault Condition
1	off	off	off	off	Not plugged into wall socket or no power from wall socket. Check circuit breaker.
2	ON	off	off	off	Not plugged into the EV or the EV is not ready to charge.
3	ON	ON	off	off	Charging enabled. Power is applied to the vehicle.
4	ON	off	- ON - not blinking	off	Improper grounding or ground is not present.
5	ON	off	off	- ON - not blinking	Problem with EV communications. Disconnect and restart.
6	ON	off	off	blinking	EV ground fault trip. Check vehicle connection.
7	ON	off	blinking	blinking	Internal EVSE fault. Call for service.

GROUNDING INSTRUCTIONS

This product must be grounded. If this product should malfunction or break down, grounding provides a path of least resistance for electric current to reduce the risk of electric shock.

The plug-in PCS is equipped with a cord having an equipment grounding conductor and a grounding plug. The plug must be plugged into an appropriate outlet that is properly installed and grounded in accordance with all local codes and ordinances.



WARNING: Improper connection of the equipment-grounding conductor may result in a risk of electric shock. Check with a qualified electrician if doubt exists as to whether the product is properly grounded. Do not modify the plug provided with the product – if it will not fit the outlet, have a proper outlet installed by a qualified electrician.

AVERTISSEMENT: Une mauvaise connexion du conducteur de terre peut entraîner un risque de choc électrique. Vérifier avec un électricien qualifié si il existe un doute quant à savoir si le produit est correctement mis à la terre. Ne pas modifier la fiche fournie avec le produit – si elle n’entre pas dans la prise, faites installer une prise adéquate par un électricien qualifié.

ADVERTENCIA: La conexión incorrecta del conductor de equipo a tierra puede resultar en un riesgo de descarga eléctrica. Consulte con un electricista calificado si existe la duda de si el producto está correctamente conectado a tierra. No modifique el enchufe suministrado con el producto – si no entra en el receptáculo, tenga un receptáculo adecuado instalado por un electricista calificado.

MOVING & STORAGE INSTRUCTIONS

When transporting the portable charge station, do not lift or carry the entire unit by the SAE J1772 charge cord. Likewise, do not lift or carry the entire unit by the NEMA wall plug.

The charge station has a non-operational storage temperature range of -40°C to $+80^{\circ}\text{C}$ (-40°F to $+176^{\circ}\text{F}$).



WARNING: For safety, always turn off input power to the EVSE at the circuit breaker panel prior to plugging it in. Likewise, turn off the circuit breaker prior to unplugging it.

AVERTISSEMENT: Pour sécurité, toujours désactiver le courant d'entrée de la station de recharge au niveau du disjoncteur du panneau avant de le brancher. De même, coupez le disjoncteur avant de le débrancher.

ADVERTENCIA: Por razones de seguridad, siempre apague la alimentación de entrada a la estación de carga en el panel de interruptores automáticos de circuito antes de enchufarlo o cablearlo a las líneas de servicio. Igualmente, apague el interruptor automático de circuito antes de desenchufarlo o desconectar la unidad de las líneas de servicio.

MAINTENANCE

The PCS requires no periodic maintenance other than occasional cleaning.



WARNING: To reduce the risk of electrical shock or equipment damage, exercise caution while cleaning the unit and the EV charge connector cable.

1. Start by unplugging the EVSE from the vehicle.
2. Unplug the EVSE from the wall receptacle before cleaning.
3. Clean the charge station using a soft cloth lightly moistened with mild detergent solution. Never use any type of abrasive pad, scouring powder, or flammable solvents such as alcohol or benzene.

AVERTISSEMENT: Pour réduire le risque de choc électrique ou des dommages équipement, user de prudence lors du nettoyage de l'appareil et le câble du connecteur de charge EV.

1. Commencer par dé brancher la station de recharge du véhicule.
2. Debrachez la station de recharge de la prise murale avante de le nettoyer.
3. Nettoyez l'équipement à l'aide d'un chiffon doux légèrement humidifié avec une solution de détergent doux. Ne jamais utiliser de tampons abrasifs, de poudre à récurer ou de solvants inflammables tels que l'alcool ou le benzène.

ADVERTENCIA: Para reducir el riesgo de descarga eléctrica o daños al equipo, debe tener cuidado durante la limpieza de la unidad y el cable del conector de carga EV.

1. Apague la estación de carga en el interruptor automático de circuito antes de la limpiar.
2. Desenchufe el EVSE del receptáculo.
3. Limpie la estación de carga con un paño suave ligeramente humedecido con una solución de detergente suave. Nunca utilice ningún tipo de

estropajo abrasivo, polvo limpiador o disolventes inflamables tales como alcohol o bencina.

NOTE: Periodic inspection of the EVSE is recommended. Visually inspect the SAE J1772 charge cable and 120V supply plug before use. If there is any damage to the SAE J1772 charge cable and/or 120V supply plug do not operate the charge station and contact a ClipperCreek Service Representative for service immediately.

REMARQUE: Une inspection périodique du EVSE est recommandée. Inspectez visuellement le câble de charge SAE J1772 et la prise d'alimentation 120V avant utilisation. Si le câble de charge SAE J1772 et/ou la fiche d'alimentation 120V sont endommagés, ne faites pas fonctionner la station de charge et contactez immédiatement un représentant du service ClipperCreek.

NOTA: Se recomienda la inspección periódica del PCS EVSE. Inspeccione visualmente el cable de carga SAE J1772 y la toma de alimentación 120V antes de usarla. Si hay algún daño en el cable de carga SAE J1772 y/o el enchufe de alimentación de 120 V, no opere la estación de carga y comuníquese con un Representante de servicio de ClipperCreek para obtener servicio de inmediato.

MOUNTING THE SAE J1772 CONNECTOR HOLSTER

The SAE J1772 connector holster comes standard to provide a convenient, protective housing for the SAE J1772 connector head when it is not in use.

- The SAE J1772 connector holster should be placed so that users have easy and safe access to the SAE J1772 connector.
- For indoor installation, mount the SAE J1772 connector holster between 18 and 48 inches above the ground or grade.
- For outdoor installation, mount the SAE J1772 connector holster between 24 and 48 inches above the ground or grade.
- The SAE J1772 connector holster has two vertically aligned mounting holes spaced 5.45” apart, one each on the enclosure top and bottom. Use a ruler or template to mark hole locations on the mounting surface.
- The vertical alignment of the PCS and SAE J1772 connector holster mounting holes allows for the convenient mounting of both components onto the same post or wall structure. For example, the holster may be mounted directly above the PCS.
- Place the SAE J1772 connector holster such that both mounting holes can take advantage of solid structural framing inside of the wall or a strong wall surface such as plywood.
- A set of exterior wood screws and stainless steel washers are included for the purposes of mounting the SAE J1772 connector holster to a wooden surface.
- For mounting to a solid surface such as concrete, brick, or stone, alternate hardware may need to be procured. Examples of solid-wall mounting hardware include multi-sets, wedge anchors and sleeve anchors. Use the type of mounting hardware most appropriate for the supporting structure.

Figure 2: Mounting the Holster Using the Exterior Wood Screws and Washers

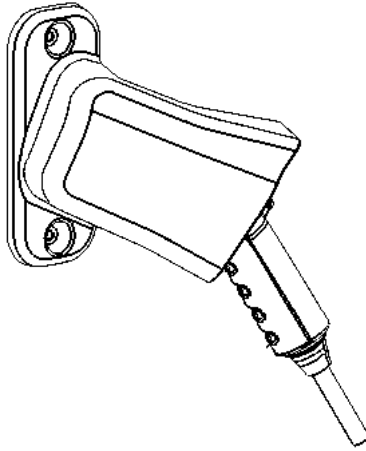
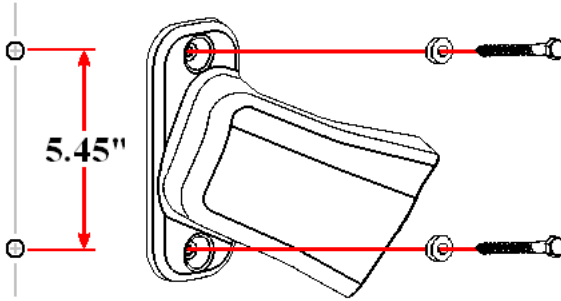

CHARGE CABLE WRAP GUIDELINES

The PCS enclosure body is sculpted to allow the charge cable to be wrapped around it for convenient storage as well as to keep the bulk of the cable off of the ground and out of the way. As the charge cable is comprised of a number of wires, coiling the charge cable too tightly around the PCS enclosure will result in the charge cable feeling warmer to the touch than would ordinarily be the case.

To minimize this effect, it is recommended that the charge cable be loosely draped around the PCS enclosure body with larger loops. This will also permit greater convenience in “pulling off” additional loops if a longer charge cable reach is desired.

Figure 3: Drape the Charge Cable Loosely Around the PCS Enclosure.

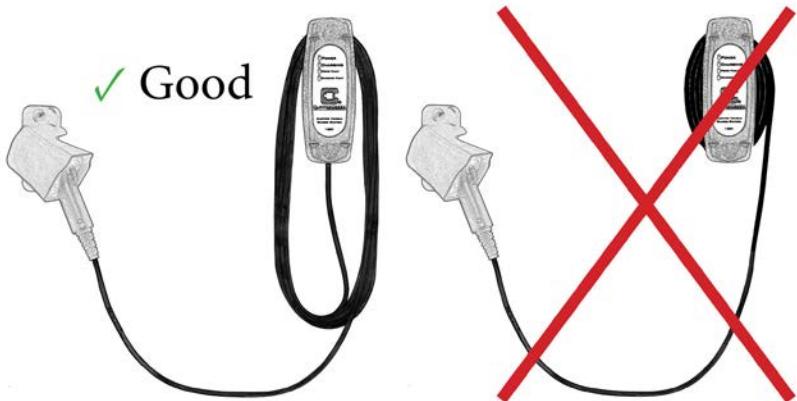

USING THE PADLOCK

A padlock with three keys is included with some ClipperCreek EVSE (when connector style permits lock hole). This rust-proof, solid brass padlock is to secure a vehicle's charge from being interrupted.

Figure 4: Locking the SAE J1772 Connector with Padlock Included

Insert Padlock into opening at the top of the SAE J1772 Connector then close to secure.

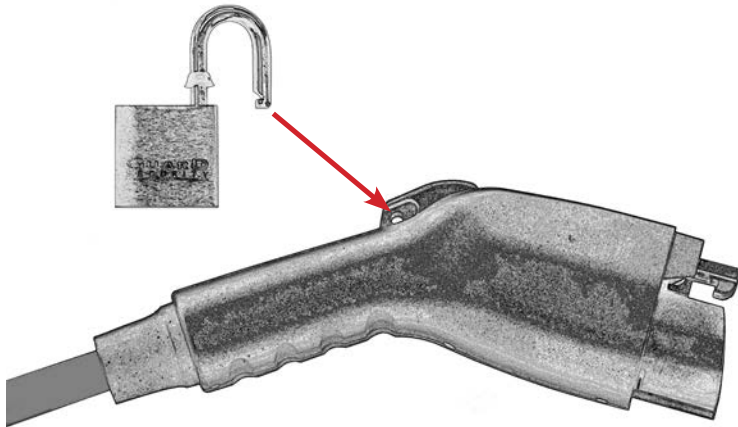
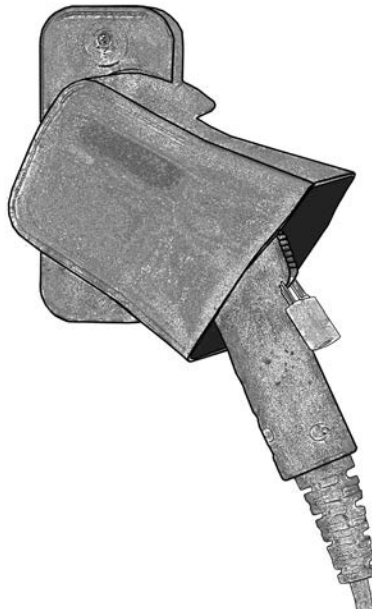

Figure 5: Charge Connector Secured with Padlock which Cannot be Removed from Vehicle without Key



Figure 6: Padlock Used in Combination with Connector Holster After Charging



NOTE: This padlock can also be used in combination with our connector holster (also included) as a low cost access control solution. Refer to **Figure 6**.

CUSTOMER SUPPORT

Call a ClipperCreek Service Representative at any time, 24 hours a day, at the number below. **PLEASE HAVE THE MODEL NUMBER AND SERIAL NUMBER AVAILABLE WHEN CALLING.**

This information is printed on the label on the side of the PCS enclosure. If a call is made after business hours or on weekends, please leave a name, telephone number, the unit serial number, and a brief description of the problem. A Customer Service Representative will call back at the earliest opportunity.

<p>Distributor Service Number Here</p>

TO CONTACT CLIPPERCREEK DIRECTLY FOR SERVICE, CALL (877) 694-4194 MONDAY THROUGH FRIDAY BETWEEN 8:00AM AND 5:00PM PACIFIC TIME.

SPECIFICATIONS

Line Input Power

Voltage & Wiring 120V AC single-phase- L1, Neutral and Ground
Voltage Range: 85V AC to 132V AC
Frequency: 60 Hz

Current &

Output Power: 120V

Circuit Breaker: 15A

Maximum Current: 12A

Output Power: 1.4kW

NOTE: *The maximum current for the vehicle is set by the duty cycle of the Pilot waveform. Output power is variable depending upon vehicle demand.*

Plugs: Attached NEMA 5-15P Plug

Dimensions: Dimensions are for the enclosure only

Height: 280 mm (11inches)

Width: 100 mm (4 inches)

Depth: 80 mm (3 inches)

Weight: 4 kg (8.5 lbs) including the SAE J1772 connector and 7.6m (25') of cable

Environment:

Operating Temp: -30°C (-22°F) to +50°C (+122°F)

Storage Temp: -40°C (-40°F) to +80°C (+176°F)

NEMA Rating NEMA 4 - watertight

Agency Approvals: cULus Listed, cETLus Listed, FCC Part 15 Class B ENERGY STAR® Certified



LIMITED WARRANTY – ELECTRIC VEHICLE SUPPLY EQUIPMENT and ACCESSORIES

Enphase Energy, Inc. through its ClipperCreek division
11850 Kemper Road
Auburn, California 95603
Phone: 877-694-4194
Email: information@clippercreek.net

Subject to the terms and conditions below, Enphase Energy, Inc. (“**Enphase**”) provides the following limited warranty the original purchaser of the products (“**Covered Owner**” or “**you**”):

Product 3-year parts, 3-year factory labor:

Subject to the terms and conditions below, Enphase warrants the product to be free from defects in material and workmanship for a period of 3 years commencing on the date of installation (first use) (the “**Warranty Start Date**”). Except where prohibited by applicable law, the product installation date must be evidenced and communicated to Enphase by way of the warranty registration card (or its equivalent). The product registration card must be filled out completely and accurately, and returned to Enphase within 30 days after installation, and the product installation date shall be within 6 months after the purchase date. If a Product installation date is not communicated to Enphase as described above, the product purchase date indicated in the Covered Owner’s proof of purchase for the product shall serve as the start date of the Warranty Period.

If Enphase confirms the existence of a defect that is covered by this Limited Warranty, Enphase will, at its option, repair or replace the product, or refund the actual purchase price for the product less reasonable depreciation based on use at the time the Enphase is notified of the defect. Enphase will not elect to issue a refund unless (i) Enphase is unable to provide a replacement and repair is not commercially practicable or cannot be timely made, or (ii) Covered Owner is willing to accept such a refund. If a defect in material or workmanship exists in the product, to the extent permitted by law, these are the sole and exclusive remedies. Repair parts and/or replacement products may be either new or reconditioned at Enphase’s discretion. This limited warranty does not cover defects caused by improper installation or use, including but not limited to improper connections with peripherals, external electrical faults, accident, disaster, misuse, abuse, or modifications to the product not approved in writing by Enphase. Any service repair outside the scope of this limited warranty shall be at applicable rates and terms then in effect. This warranty covers factory parts and factory labor only; it does not cover field service or removal and replacement of the product or any other costs.

All other express and implied warranties for this product including the warranties of merchantability, fitness for a particular purpose, and non-infringement are hereby disclaimed. Some states do not allow the exclusion of implied warranties or limitations on how long an implied warranty lasts, so the above limitation may not apply to you. In no event will Enphase, any of its authorized sales and service representatives, or its parent company be liable to Covered Owner or any third party for any damages in excess of the purchase price of the product. This limitation applies to damages of any kind including any direct or indirect damages, lost profits, lost saving or other special, incidental, exemplary or consequential damages whether for breach of contract, tort or otherwise or whether arising out of the use of or inability to use the product, even if Enphase or an authorized Enphase representative or dealer has been advised of the possibility of such damages or of any claim by any other party. Some states do not allow the exclusion or limitation of incidental damages for some products, so the above limitation or exclusion may not apply to you. This warranty gives you specific legal rights, and you may also have other rights which may vary from state to state.

To obtain warranty service:

Call your nearest authorized Service Representative or the ClipperCreek division of Enphase at the above number. You will receive information as to how service for the product will be provided. If you mail or ship the product in for service, you must insure the product, prepay all shipping charges, and properly pack it for shipment in its original shipping container or its equivalent. You are responsible for all loss or damage that may occur in transit. You must provide proof of purchase for the product and the purchase date before any warranty service can be performed.

This page is intentionally blank.

This page is intentionally blank.



CLIPPERCREEK

A division of Enphase Energy, Inc.

WWW.CLIPPERCREEK.COM

877-694-4194