

IQ8P Microinverters



Applicable regions: Philippines

© 2024 Enphase Energy. All rights reserved. Enphase, the e and CC logos, IQ, and certain other marks listed at <https://enphase.com/trademark-usage-guidelines> are trademarks of Enphase Energy, Inc. in the U.S. and other countries. Data subject to change.

Contents

1	The Enphase Energy System.....	10
1.1	How the Enphase IQ Series Microinverters work.....	10
1.1.1	System monitoring.....	11
1.1.2	Optimal reliability.....	11
1.1.3	Ease of design.....	11
2	Planning for microinverter installation.....	11
2.1	Compatibility.....	12
2.2	Grounding considerations.....	12
2.3	Branch circuit capacity.....	12
2.4	Utility service requirements.....	13
2.5	Wire lengths and voltage rise.....	13
2.6	Lightning and surge suppression.....	13
3	Parts and tools required.....	14
3.1	Enphase equipment.....	14
3.2	Other items.....	14
4	Enphase microinverter installation.....	14
4.1	Position the IQ Cable.....	16
4.2	Position the junction box.....	16
4.3	Mount the microinverters.....	16
4.4	Create an installation map.....	17
4.5	Manage the cabling.....	18
4.6	Connect the microinverters.....	19
4.7	Terminate the unused end of the cable.....	19
4.8	Complete the installation of the junction box.....	20
4.9	Connect the PV modules.....	20
4.10	Enphase Energy System configuration.....	21
4.11	Set up and activate monitoring.....	22
5	Troubleshooting.....	22

5.1	Status LED indications and error reporting.....	23
5.1.1	LED operation.....	23
5.1.2	DC Resistance Low – Power off condition.....	23
5.1.3	Other faults.....	24
5.2	Troubleshoot an inoperable microinverter.....	24
5.3	Disconnect a microinverter.....	25
5.4	Install a replacement microinverter.....	26
6	Replacement parts and cabling.....	26
6.1	Enphase IQ Cable planning and ordering.....	27
6.2	Connector spacing options.....	27
6.3	IQ Cable options.....	27
6.4	Enphase IQ Cable accessories.....	28
7	Technical data.....	28
7.1	Technical considerations.....	28
7.2	Bifacial modules.....	28
8	Specifications.....	29
8.1	IQ8P-72-2-US Microinverters.....	29
8.2	IQ Cable specifications.....	31
8.3	Enphase connector ratings.....	32
9	Enphase installation map.....	32
10	Sample single-phase wiring diagram.....	33
11	Sample three-phase wiring diagram.....	34
12	Revision history.....	35

Corporate headquarters contact information

Enphase Energy, Inc.
47281 Bayside Pkwy, Fremont, CA 94538,
United States of America, PH: +1 (707) 763-4784
<https://enphase.com/contact/support>

FCC compliance

This equipment has been tested and found to comply with the limits for a Class B digital device, pursuant to part 15 of the FCC Rules. These limits are designed to provide reasonable protection against harmful interference in a residential installation. This equipment generates, uses, and can radiate radio frequency energy and, if not installed and used in accordance with the instructions, may cause harmful interference to radio communications. However, there is no guarantee that interference will not occur in a particular installation. If this equipment does cause harmful interference to radio or television reception, which can be determined by turning the equipment off and on, you are encouraged to try to correct the interference by one or more of the following measures:

- Reorient or relocate the receiving antenna.
- Increase the separation between the equipment and the receiver.
- Connect the equipment to an outlet on a circuit different from that to which the receiver is connected.
- Consult the dealer or an experienced radio/TV technician for help.

Changes or modifications not expressly approved by the party responsible for compliance may void the user's authority to operate the equipment.

Other information

Product information is subject to change without notice. All trademarks are recognized as the property of their respective owners.

User documentation is updated frequently; check the Enphase website for the latest information <https://enphase.com/en-ph/installers/resources/documentation>.

To ensure optimal reliability and to meet warranty requirements, the Enphase microinverter must be installed according to the instructions in this manual. For warranty text, refer to enphase.com/installers/resources/warranty.

For Enphase patent information, refer to <https://enphase.com/patents>.

Audience

This manual is intended for use by professional installation and maintenance personnel.

Important safety information

Read this first

This manual contains important instructions for use during the installation and maintenance of the IQ8 Series Microinverters.



IMPORTANT: Enphase IQ Series Microinverters require the IQ Cable. An IQ Gateway is required to monitor the performance of the IQ Microinverters and configure them to be compliant with certain Authority Having Jurisdictions (AHJs). The IQ accessories work only with IQ Series Microinverters.

Product labels

The following symbols appear on the product label and are described here.



Hot surface



Refer to safety instructions



Risk of electric shock



Refer to the manual



Double insulated

Safety and advisory symbols

To reduce the risk of electric shock and to ensure the safe installation and operation of the IQ8 Series Microinverters System, the following safety symbols appear throughout this document to indicate dangerous conditions and important safety instructions.



DANGER: This indicates a hazardous situation, which, if not avoided, will result in death or serious injury.



WARNING: This indicates a situation where failure to follow instructions may be a safety hazard or cause equipment malfunction. Use extreme caution and follow instructions carefully.



WARNING: This indicates a situation where failure to follow instructions may result in burn injury.



NOTE: This indicates information that is very important for optimal system operation. Follow instructions closely.

IQ8 Series Microinverters safety instruction

General safety



DANGER: Risk of electric shock. Risk of fire.

Only use electrical system components approved for wet locations.

Only qualified personnel should install, troubleshoot, or replace Enphase microinverters or IQ Cable and accessories.

Ensure that all AC and DC wiring is correct and that none of the AC or DC cables are pinched, shorted, or damaged. Also, ensure that all AC junction boxes are properly closed.

Do not exceed the maximum number of microinverters in an AC branch circuit as listed in the manual. You must protect each microinverter AC branch circuit with a breaker or fuse of 20 A or 25 A for single-phase and multi-phase systems. Note that single-phase IQ Relay is rated for 20 A, whereas multi-phase IQ Relay is rated for 25 A.

Do not use Enphase equipment in a manner not specified by the manufacturer. Doing so may cause death or injury to persons or damage to equipment.

Be aware that installation of this equipment includes the risk of electric shock.

The DC conductors of this photovoltaic system are ungrounded and may be energized.

Always de-energize the AC branch circuit before servicing. Never disconnect the DC or AC connectors under load.



WARNING: Before installing or using the Enphase microinverter, read all instructions and cautionary markings in the technical description of the Enphase equipment and the photovoltaic (PV) equipment.

Do not connect Enphase microinverters to the grid or energize the AC circuit(s) until you have completed all the installation procedures and have received approval from the electrical network operator.

When the PV array is exposed to light, DC voltage is supplied to the power conversion equipment (PCE).

Risk of equipment damage. Enphase male and female connectors must only be mated with the identical type and brand of male/female connector.



NOTE: To ensure optimal reliability and to meet warranty requirements, install the Enphase equipment according to the instructions in this manual. The AC and DC connectors on the cabling are rated as a disconnect only when used with an Enphase microinverter. Protection against lightning and resulting voltage surges must be in accordance with local electrical codes and standards. Perform all electrical installations in accordance with all applicable local electrical codes and standards.

Microinverter safety



WARNING: Risk of skin burn.

Microinverter safety

The chassis of the Enphase microinverter is the heat sink. Under normal operating conditions, the temperature could be 20°C above ambient temperature, but under extreme conditions, the microinverter can reach a temperature of 90°C. To reduce the risk of burns, use caution when working with microinverters.



DANGER: Risk of fire.

The DC conductors of the PV module must be labeled PV Wire or PV Cable when paired with the Enphase microinverter.



DANGER: Risk of electric shock. Risk of fire.

Only competent personnel may connect the Enphase microinverter to the electricity grid.

Do not attempt to repair the Enphase microinverter; it contains no user-serviceable parts. If it fails, contact [Enphase Support](#) to obtain a return merchandise authorization (RMA) number and start the replacement process. Tampering with or opening the Enphase microinverter will void the warranty.



WARNING: Risk of equipment damage.

Install the microinverter under the PV module to avoid direct exposure to rain, UV, and other harmful weather events. Always install the microinverter bracket side up. Do not mount the microinverter upside down. Do not expose the AC or DC connectors (on the IQ Cable, PV module, or microinverter) to rain or condensation before the connectors are mated.

The maximum open circuit voltage of the PV module must not exceed the specified maximum input DC voltage of the Enphase microinverter. Refer to the Enphase compatibility calculator at <https://enphase.com/en-ph/installers/microinverters/calculator> to verify PV module electrical compatibility with the microinverter. Use IQ8 Series Microinverters only with compatible PV modules as per the Enphase compatibility calculator. Using an electrically incompatible PV module voids Enphase warranty.

You must match the DC operating voltage range of the PV module with the allowable input voltage range of the Enphase microinverter.

The Enphase microinverter is not protected from damage due to moisture trapped in cabling systems. Never mate microinverters to cables that have been left disconnected and exposed to wet conditions. This voids the Enphase warranty.

The Enphase microinverter functions only with a standard, compatible PV module with appropriate fill factor, voltage, and current ratings. Unsupported devices include smart PV modules, fuel cells, wind or water turbines, DC generators, non-Enphase batteries, and so on. These devices do not behave like standard PV modules, so operation and compliance are not guaranteed. These devices may also damage the Enphase microinverter by exceeding its electrical rating, making the system potentially unsafe.



NOTE: The Enphase microinverter has field-adjustable voltage and frequency trip points that may need to be set, depending upon local requirements. Contact Enphase Support at <https://enphase.com/en-ph/contact> for required modifications as per local requirements.



NOTE: Installers must check the manufacturing date of the products to ensure that the installation date is within one year of the manufactured date of the products. Contact your local distributor to validate the date code.

Enphase IQ Cable safety



DANGER: Risk of electric shock.

Do not install the IQ Terminator while the power is connected.



WARNING: Risk of electric shock. Risk of fire.

When stripping the sheath from the IQ Cable, ensure the conductors are not damaged. If the exposed wires are damaged, the system may not function properly.

Do not leave AC connectors on the IQ Cable uncovered for an extended period. You must cover any unused connector with a sealing cap.

Ensure protective sealing caps have been installed on all the unused AC connectors. Unused AC connectors are live when the system is energized.

Use the terminator only once. If you open the terminator following installation, the latching mechanism is destroyed. If the latching mechanism is defective, do not use the terminator. Do not circumvent or manipulate the latching mechanism.

Secure any loose cable when installing the IQ Cable to minimize tripping hazards.



NOTE: When looping the IQ Cable, do not form loops smaller than 12 cm (4.75") in diameter.

Provide support for the IQ Cable every 1.8 m (6 ft).

If you need to remove a sealing cap, you must use the IQ Disconnect Tool.

When installing the IQ Cable and accessories, adhere to the following:

- Do not expose the terminator cap or cable connections to directed, pressurized liquid (water jets, and so on).
- Do not expose the terminator or cable to continuous immersion.
- Do not expose the terminator cap or cable connections to continuous tension (for example, tension due to pulling or bending the cable near the connection).
- Use only the connectors provided.
- Do not allow contamination or debris in the connectors.
- Use the terminator cap and cable connections only when all parts are present and intact.
- Do not install or use in potentially explosive environments.
- Do not allow the terminator to come into contact with an open flame.
- Fit the terminator cap using only the prescribed tools and in the prescribed manner.
- Use the terminator to seal the conductor end of the IQ Cable; no other method is allowed.

PV rapid shutdown equipment (PVRSE)

This product is UL Listed as PV rapid shutdown equipment and conforms with NEC-2014, NEC-2017, and NEC-2020 section 690.12 and C22.1-2018 Rule 64-218 rapid shutdown of PV systems, for AC and DC conductors, when installed according to the following requirements:

- Microinverters and all DC connections must be installed inside the array boundary. Enphase further requires that the microinverters and DC connections be installed under the PV module to avoid direct exposure to rain, UV, and other harmful weather events.

- The array boundary is defined as 305 mm (1 ft.) from the array in all directions or 1 m (3 ft.) from the point of entry inside a building.

This rapid shutdown system must be provided with an initiating device or status indicator installed in a location accessible to first responders. Alternately, it must be connected to an automatic system that initiates rapid shutdown in the event a system disconnects or another emergency system is activated. The initiator shall be listed and identified as a disconnecting means that plainly indicates whether it is in the OFF or ON position. Examples are:

- Service disconnecting means
- PV system disconnecting means
- Readily accessible switch or circuit breaker

The handle position of a switch or circuit breaker is suitable for use as an indicator. Refer to NEC or CSA C22.1-2018 for more information.

Additionally, in a prominent location near the initiator device, a placard or label must be provided with a permanent marking including the following wording:

PHOTOVOLTAIC SYSTEM EQUIPPED WITH RAPID SHUTDOWN. The term **PHOTOVOLTAIC** may be replaced with **PV**.

The placard, label, or directory shall be reflective, with all letters capitalized and having a minimum height of 9.5 mm (3/8") in white on a red background.

Anti-islanding methodology

The anti-islanding methodology used by Enphase IQ8P Microinverters is listed by UL and tested in accordance with IEEE 1547-2018 and UL1741-SB.

IQ8 Series Microinverter uses the Group 1 method of anti-islanding based on the definitions provided in the list below as defined in [Sand2018-8431, July 2018](#):

- Group 1: Frequency shift with continuous positive frequency feedback.
- Group 2A: Frequency shift with discontinuous or stepped positive frequency feedback.
- Group 2B: Frequency shift like Group 2A except with a dead zone around 60 Hz.
- Group 2C: Frequency shift with unidirectional frequency feedback.
- Group 3: Monitors change of impedance.
- Group 4: Monitors shift at a harmonic frequency (multiple of the fundamental).
- Group 5: Passive methods like rate of change of frequency and vector shift.
- Group 6: Produces negative sequence current and monitors voltage.

For any questions, contact <https://enphase.com/en-ph/contact>.

1. The Enphase Energy System

The Enphase Energy System includes:

- **IQ8P Microinverters:** The smart grid-ready IQ8P Microinverters convert the DC output of the PV module into grid-compliant AC power.
- **IQ Gateway:** An IQ Gateway (model ENV-S-AM1-230-60 or ENV-IQ-AM3-3P) is required to monitor solar production, propagate a grid profile to the microinverters, and provide microinverter control at sites where power export limitation (PEL) and phase imbalance management (PIM) is required through advanced grid functionalities.

The IQ Gateway is a communication device that provides network access to the PV array. The IQ Gateway collects production and performance data from the IQ8P Microinverters over onsite AC power lines and transmits the data to the Enphase App through a broadband or cellular connection. The IQ Gateway can monitor up to 600 IQ8P Microinverters and 39 IQ Batteries.



NOTE: All installations require that you use the Enphase IQ Gateway to commission the microinverters to propagate correct grid profile settings. This will also ensure that the microinverter's firmware is upgraded whenever a newer version is available.

- **Enphase Installer Portal:** A web-based monitoring and management software. Installers can use the Enphase Installer Portal to view detailed performance data, manage multiple PV systems, and remotely resolve issues that might impact system performance. Find out more at enphase.com/enlighten.
- **Enphase Installer App:** A mobile app for iOS and Android devices. It allows installers to configure the system while onsite, eliminating the need for a laptop and improving installation efficiency. You can use the app to:
 - Connect to the IQ Gateway over a wireless network for faster system setup and verification.
 - View and e-mail a summary report that confirms a successful installation.
 - Scan device serial numbers and sync system information with the Enphase Installer Portal.
- **IQ Field Wireable Connectors (Q-CONN-10F and Q-CONN-10M):** Make connections from any IQ Cable or open the IQ Field Wireable Connector.

This manual describes the safe installation and operation of the IQ8P Microinverters.



NOTE: To ensure optimal reliability and to meet warranty requirements, Enphase microinverters must be installed according to the instructions in this manual.

1.1 How the Enphase IQ Series Microinverters work

The Enphase microinverter maximizes energy production by using a sophisticated maximum power point tracking (MPPT) algorithm. Each microinverter individually connects to one PV module in your array. This configuration enables an individual MPPT to control each PV module, ensuring that the maximum power available from each PV module is exported to the utility grid regardless of the performance of the other PV modules in the array. While an individual PV module in the array may be affected by shading, soiling, orientation, or PV module mismatch, each microinverter ensures top performance for its associated PV module.

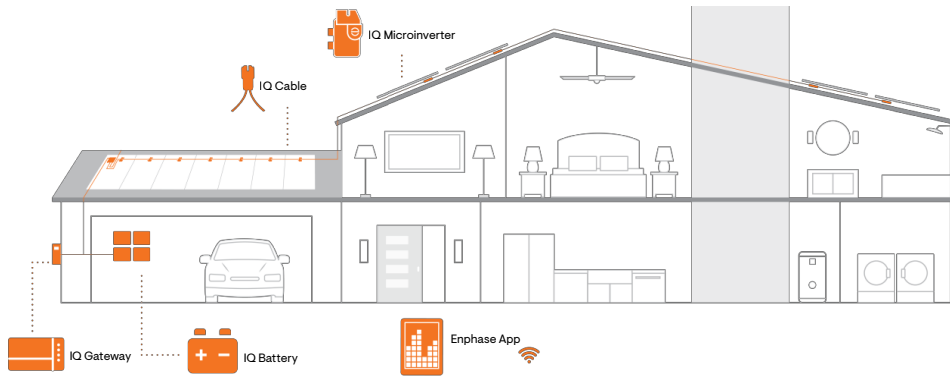

1.1.1 System monitoring

Once you install the IQ Gateway and provide an internet connection through a broadband router or modem, the IQ Microinverters automatically begin reporting to the Enphase Installer Portal. The Enphase Installer Portal presents current and historical system performance trends and informs you of PV system status.

1.1.2 Optimal reliability

Microinverter systems are inherently more reliable than traditional inverters. The distributed nature of a microinverter system ensures that there is no single point of system failure in the PV system. Enphase microinverters are designed to operate at full power at ambient temperatures as high as 60°C (140°F).

1.1.3 Ease of design

PV systems using Enphase microinverters are very simple to design and install. You will not need string calculations or cumbersome traditional inverters. You can install individual PV modules in any combination of PV module quantity, type, age, and orientation. Each microinverter quickly mounts on the PV racking directly beneath each PV module. Low-voltage DC wires connect from the PV module directly to the co-located microinverter, eliminating the risk of personnel exposure to dangerously high DC voltage.

2. Planning for microinverter installation

The microinverter housing is designed for outdoor installation and complies with the NEMA 250, type 6 environmental enclosure rating standard.

 **NOTE: NEMA 6 rating definition:** Indoor or outdoor use primarily to provide a degree of protection against hose-directed water, the entry of water during occasional temporary submersion at a limited depth, and damage from external ice formation.

The IQ Cable is available with connector spacing options to accommodate the installation of PV modules in portrait or landscape orientation. For IQ Cable ordering information, refer to [Enphase IQ Cable planning and ordering](#).

2.1 Compatibility

The IQ8P Microinverters are electrically compatible with PV modules, as listed in the following table. No enforced DC/AC ratio and maximum input power. Modules can be paired if the open circuit voltage (V_{OC}) and short circuit current (I_{SC}) of the PV module at the extreme temperatures (lowest temperature for voltage and highest temperature for current) do not exceed the microinverter’s maximum input DC voltage and maximum module I_{SC} specifications respectively.

For specifications, see [Specifications](#) on page 29. You can refer to the Enphase compatibility calculator at <https://enphase.com/en-ph/installers/microinverters/calculator> to verify PV module electrical compatibility. To ensure mechanical compatibility, the microinverter’s male and female connectors must only be mated with the identical type and brand of male and female connectors.



WARNING: Risk of fire. The PV module DC conductors must be labeled “PV Wire” or “PV Cable” to comply with NEC for ungrounded PV power systems.

Microinverter model	Connector type	PV module cell count
IQ8P-72-2-US	Stäubli MC4	Pair with 60-cell/120-half-cell, 66-cell/132-half-cell, 72-cell/144-half-cell, 78-cell/156-half-cell

- NOTE:** IQ8 Series Microinverters can be added to existing IQ7 systems on the same IQ Gateway in the Solar Only grid-tied configuration without backup.
- NOTE:** IQ7 Series Microinverters cannot be added to a site that already has IQ8 Series Microinverters connected to the same IQ Gateway.
- NOTE:** Adding IQ8 Series Microinverters to an existing IQ7 system with an IQ System Controller is not supported if they are connected to the same IQ Gateway.

2.2 Grounding considerations

The microinverter models listed in this guide do not require grounding electrode conductors (GEC), equipment grounding conductors (EGC), or grounded conductors (neutral). Your Authority Having Jurisdiction (AHJ) may require you to bond the mounting bracket to the racking. If so, use UL 2703 hardware or star washers. The microinverter itself has a Class II double-insulated rating, which includes ground fault protection (GFP). To support GFP, use only PV modules equipped with DC cables labeled “PV Wire” or “PV Cable.”

2.3 Branch circuit capacity

Plan your AC branch circuits to meet the following limits for a maximum number of microinverters per branch when protected with a 20 A (maximum) overcurrent protection device (OCPD). The maximum allowed number of IQ8P Microinverters (230 VAC) per AC branch circuit is seven.

- NOTE:** Limits may vary. Refer to local requirements to define the number of microinverters per branch in your area.

- 
NOTE: For a mixed system with both IQ7 and IQ8 Microinverters on the same branch, ensure that the total maximum continuous output current of all microinverters on the branch does not exceed 16 A.

2.4 Utility service requirements

The IQ Series Microinverters work with single-phase service. Measure AC line voltages at the electrical utility connection to confirm that it is within the ranges shown.

240 VAC, single-phase	
L1 to L2	211 to 264 VAC
L1, L2 to ground	106 to 132 VAC
240 VAC, single-phase	
L1 to L2	198 to 242 VAC
L1, L2 to ground	106 to 132 VAC

- 
NOTE: All installations require that you use the Enphase IQ Gateway to commission the microinverters to propagate correct grid profile settings. This will also ensure that the microinverter’s firmware is upgraded whenever a newer version is available.

2.5 Wire lengths and voltage rise

When planning the system, you must select the appropriate AC conductor size to minimize voltage rise. Select the correct wire size based on the distance from the beginning of the microinverter AC branch circuit to the breaker in the load center. Enphase recommends a voltage rise total of less than 2% for the sections from the microinverter AC branch circuit to the breaker in the load center.

Enphase provides guidance about choosing wire size and maximum conductor lengths in the [Voltage rise technical brief](#). Refer to this brief for voltage rise values in IQ Cables and on how to calculate voltage rise in other wire sections of the system.

Standard guidelines for voltage rise on feeder and AC branch circuit conductors might not be sufficient for microinverter AC branch circuits that contain the maximum allowable microinverters. This is due to the high inherent voltage rise on the AC branch circuit.

- 
NOTE: Best practice: Center-feed the branch circuit to minimize voltage rise in a fully populated branch. This practice greatly reduces the voltage rise as compared with an end-fed branch. To center-feed a branch, divide the circuit into two sub-branch circuits protected by a single OCPD.

2.6 Lightning and surge suppression

Enphase microinverters have integral surge protection, greater than most traditional inverters. However, if the surge has sufficient energy, the protection built into the microinverter can be exceeded, and the equipment can be damaged. For this reason, Enphase recommends that you

protect your system with a lightning and/or surge suppression device. In addition to having some level of surge suppression, it is also important to have insurance that protects against lightning and electrical surges. Enphase has tested the following devices:

- [Leviton 51110-SRG](#)
- [Schneider SquareD HEPD50](#)



NOTE: Protection against lightning and resulting voltage surges must be in accordance with local standards.

3. Parts and tools required

In addition to the microinverters, PV modules, and racking, you will need the following.

3.1 Enphase equipment

- IQ Gateway: Required to monitor production and configure microinverters to be compliant with certain AHJs. IQ Gateway models are ENV-S-AM1-230-60 and ENV-IQ-AM3-3P.
- Enphase Installer App: Download the Enphase Installer App, open it, and log in to your Enphase Account. Use it later to scan microinverter serial numbers and connect to the IQ Gateway to track system installation progress. To download it, go to <https://enphase.com/installers/apps> or scan the QR code.



- Tie wraps or IQ Cable Clips (Q-CLIP-100)
- IQ Sealing Caps (Q-SEAL-10) for any unused drops on the IQ Cable.
- IQ Terminator (Q-TERM-10): Typically, two are needed per branch circuit.
- IQ Disconnect Tool (Q-DISC-10)
- IQ Field Wireable Connectors (male and female: Q-CONN-10M and Q-CONN-10F)
- IQ Cable. For more information, see [IQ Cable options](#) on page 27.

3.2 Other items

- AC junction box
- Number 2 and 3 screwdrivers
- Wire cutters, voltmeter
- Torque wrench, sockets, wrenches for mounting hardware
- Power drill or impact driver

4. Enphase microinverter installation

Installing the Enphase IQ Series Microinverters involves several key steps. Each step listed here is detailed in the following pages.

1. Position the IQ Cable.
2. Position the junction box.
3. Mount the microinverters.
4. Create an installation map.
5. Manage the cabling.
6. Connect the microinverters.
7. Terminate the unused end of the cable.
8. Complete the installation of the junction box.
9. Connect the PV modules.
10. Energize the system.

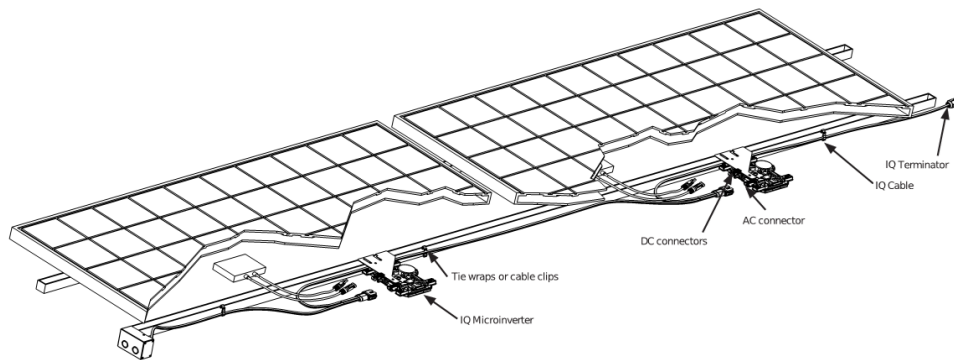

Figure 1: Horizontal mount

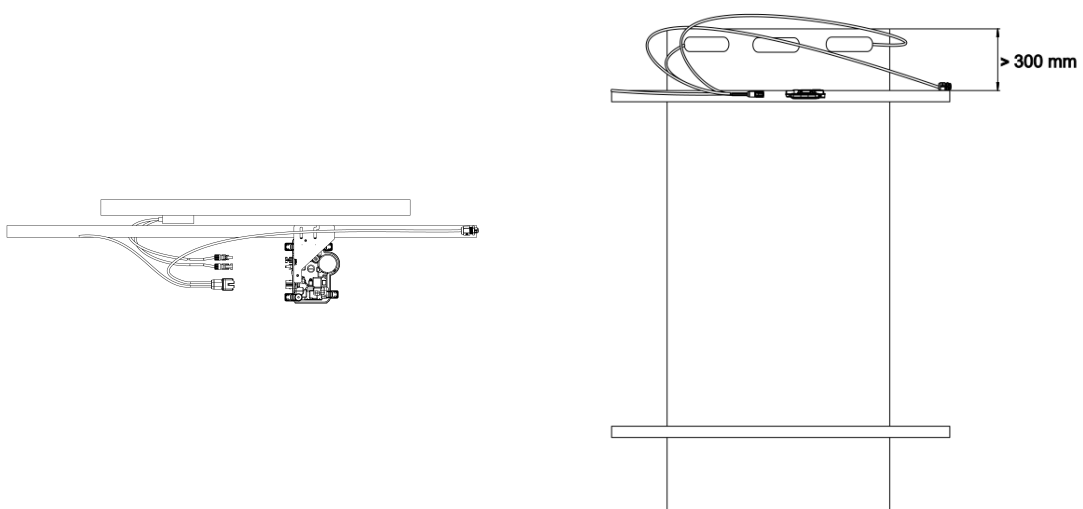

Figure 2: Vertical mount

4.1 Position the IQ Cable

- Plan each cable segment to allow drop connectors on the IQ Cable to align with each PV module. Allow extra length for slack, cable turns, and any obstructions.
- Mark the approximate centers of each PV module on the PV racking.
- Lay out the cabling along the installed racking for the AC branch circuit.
- Cut each segment of cable to meet your planned needs.



WARNING: When transitioning between rows, secure the cable to the rail to prevent cable damage or connector damage. Do not count on the connector to withstand tension.

4.2 Position the junction box

1. Verify that the AC voltage at the site is within range.

Service type and voltage: L1-L2	
240 VAC split-phase	211 to 264 VAC
220 VAC single-phase	198 to 242 VAC
220 VAC three-phase	198 to 242 VAC



NOTE: All installations require that you use the Enphase IQ Gateway to commission the microinverters to propagate correct grid profile settings. This will also ensure that the microinverter’s firmware is upgraded whenever a newer version is available.

2. Install a junction box at a suitable location on the racking.
3. Provide an AC connection from the junction box back to the electricity network using equipment and practices as required by local jurisdictions.

4.3 Mount the microinverters

1. Mount the microinverter horizontally, bracket side up, or vertically.
 - Always place the microinverter under the PV module, protected from direct exposure to rain, sun, and other harmful weather events. Allow a minimum of 1.9 cm (3/4") between the roof and the microinverter. Also, allow 1.3 cm (1/2") between the back of the PV module and the top of the microinverter.
 - For vertical mount, also maintain >30 cm (12") clearance from the edges of the PV module to protect the microinverter from direct exposure to rain, UV, and other harmful weather events.



WARNING: Install the microinverter under the PV module to avoid direct exposure to rain, UV, and other harmful weather events. Do not mount the microinverter upside down.

2. Torque the microinverter fasteners as follows. Do not over-torque.
 - 6 mm (1/4") mounting hardware: 5 N m (45 to 50 in-lb)
 - 8 mm (5/16") mounting hardware: 9 N m (80 to 85 in-lb)
 - When using UL 2703 mounting hardware, use the manufacturer’s recommended torque value.

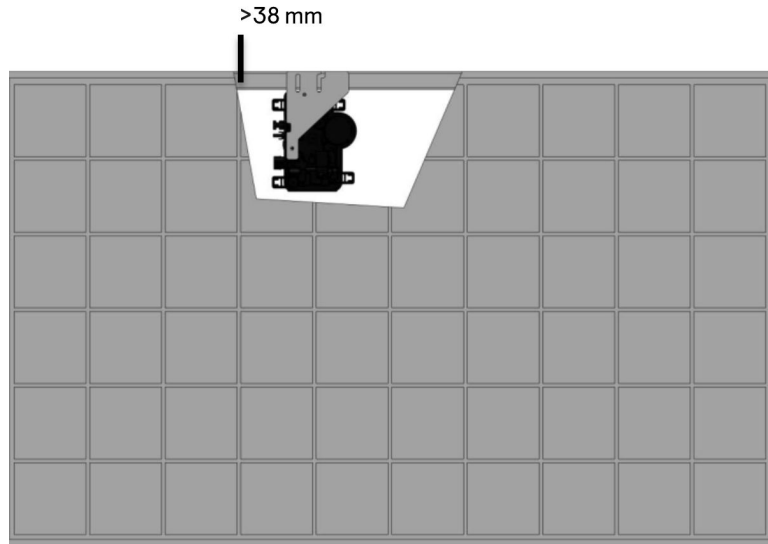

Figure 3: Horizontal mount

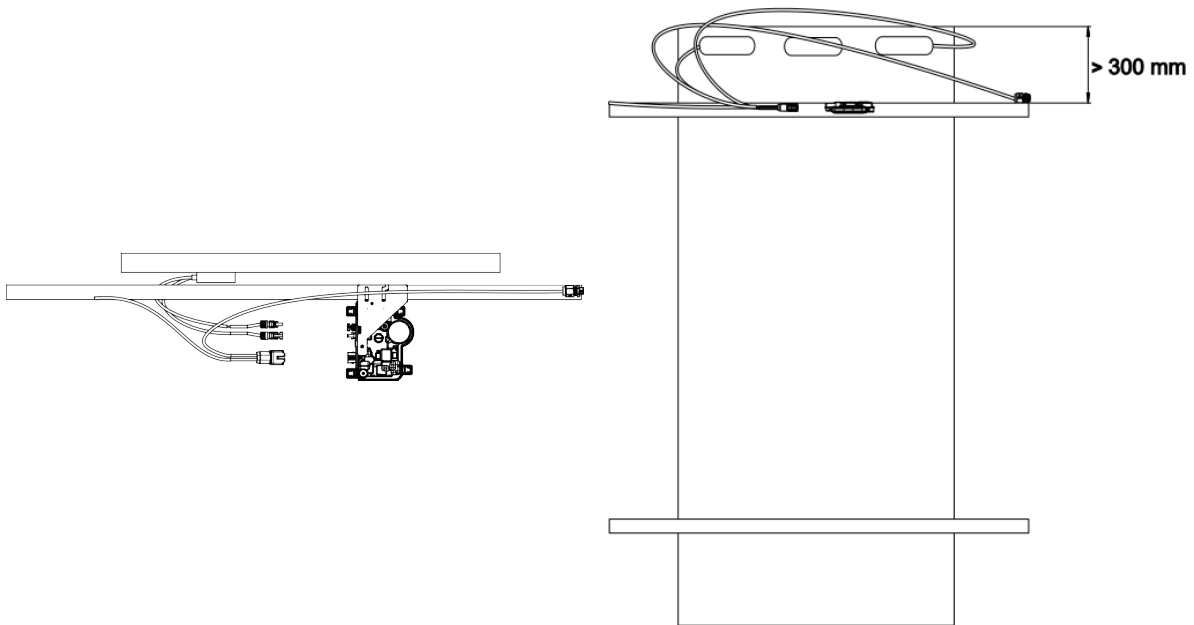

Figure 4: Vertical mount

4.4 Create an installation map

The Enphase installation map is a diagram of the physical location of each microinverter in your PV installation. Copy or use the blank [Enphase installation map](#) to record microinverter placement for the system, or provide your own layout if you require a larger or more intricate installation map.

Each Enphase microinverter and IQ Gateway has a removable serial number label. Build the installation map by peeling the serial number labels from the microinverter mounting plates and placing the labels on the map. You must also place the IQ Gateway serial number on the map after installation.

After you have created the installation map, use the Enphase Installer App (mobile app) to record serial numbers and configure the system.

For details, refer to **Detect the Microinverters** in the help topics of the Enphase Installer App.

- Peel the removable serial number label from each microinverter and affix it to the respective location on the paper installation map.
- Peel the label from the IQ Gateway and affix it to the installation map.
- Always keep a copy of the installation map for your records.

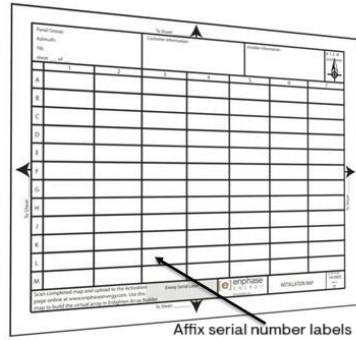

4.5 Manage the cabling

1. Use cable clips or tie wraps to attach the cable to the racking. Leave no more than 1.8 m (6 ft) between cable clips or tie wraps.

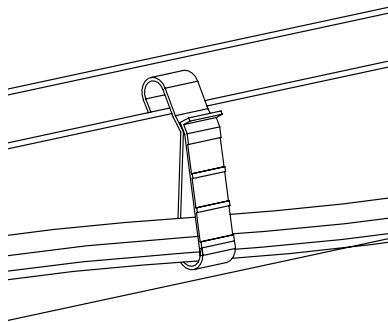

2. Dress any excess cabling in loops so that it does not contact the roof. Do not form loops smaller than 12 cm (4¾") in diameter.



WARNING: Tripping hazard. Loose cables can become a tripping hazard. Dress the IQ Cable to reduce this risk.

4.6 Connect the microinverters

1. Connect the microinverter. Listen for a click as the connectors engage.
2. Cover any unused connector with IQ Sealing Caps. Listen for a click as the connectors engage.

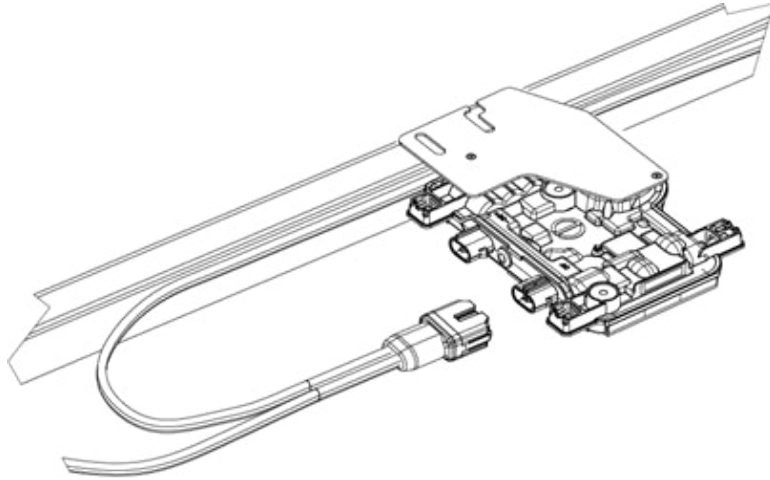

WARNING: Risk of electric shock. Risk of fire. Install sealing caps on all unused AC connectors, as these connectors become live when the system is energized. Sealing caps are required for protection against moisture ingress.



NOTE: If you need to remove a sealing cap, you must use the IQ Disconnect Tool. Refer to [Disconnect a microinverter](#).

4.7 Terminate the unused end of the cable

Terminate the unused end of the Enphase IQ Cable as follows.

1. Remove 13 mm (½ inch) of the cable sheath from the conductors. Use the terminator loop to measure 13 mm.

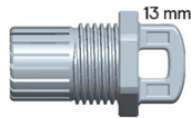

2. Slide the hex nut onto the cable.
3. Insert the cable into the terminator body so that each of the two wires lands on opposite sides of the internal separator. There is a grommet inside of the hex nut that should remain in place.

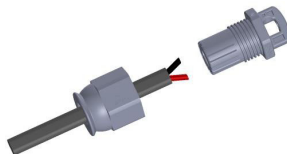

4. Insert a screwdriver into the slot on the top of the terminator to hold it in place and torque the nut to 7 N m.

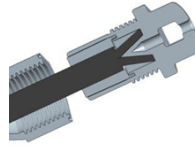

5. Hold the terminator body stationary with the screwdriver and turn only the hex nut to prevent the conductors from twisting out of the separator.



NOTE: Turn only the hex nut to prevent conductors from twisting out of the separator.

6. Attach the terminated cable end to the PV racking with a cable clip or tie wrap so that the cable and terminator do not touch the roof.



WARNING: The terminator cannot be re-used. If you unscrew the nut, you must discard the terminator.

4.8 Complete the installation of the junction box

1. Connect the IQ Cable to the junction box.
2. Refer to the [Sample single-phase wiring diagram](#) for more information. Wire colors are listed in the following table.

Wire colors

L1-black

L2-red

4.9 Connect the PV modules



WARNING: Electrical shock hazard. The DC conductors of this photovoltaic system are ungrounded and may be energized.

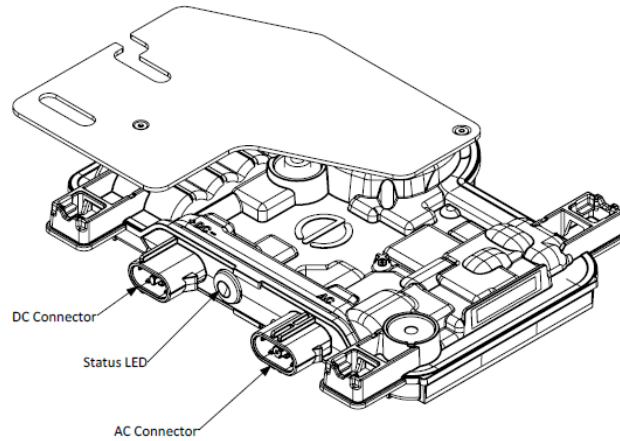

1. If required, attach the DC bulkhead adaptors to the microinverters. Ensure they are fully seated. Do not reverse the adaptor connections.
2. Connect the DC leads of each PV module to the DC input connectors of the corresponding microinverter.
3. Check the LED on the connector side of the microinverter. The LED flashes six times when DC power is applied.
4. Mount the PV modules above the microinverters.

4.10 Enphase Energy System configuration

The Enphase Energy System with IQ8P Microinverters can be used to form the PV solar grid-tied configuration.

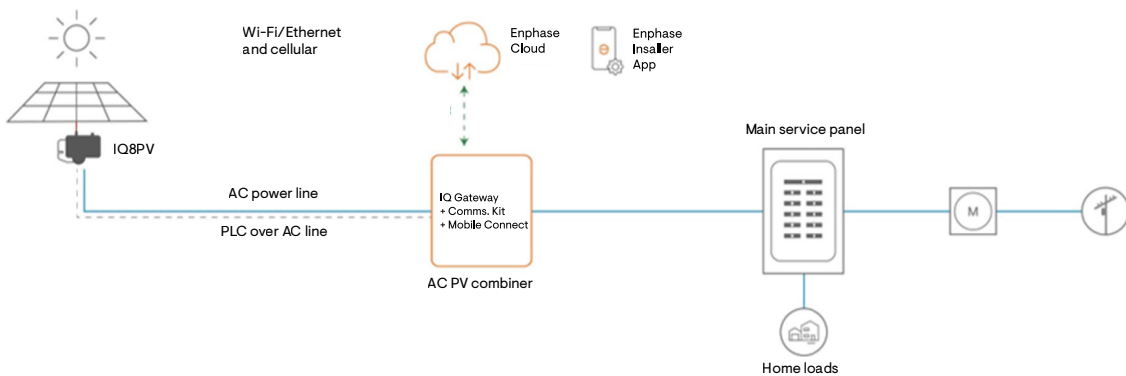

Figure 5: Enphase Energy System PV solar grid-tied

For grid-tied mode, after the IQ8 Microinverter installation, energize the system as follows:

1. Turn ON the AC disconnect or circuit breaker for the branch circuit.
2. Turn ON the main utility grid AC circuit breaker. Your system starts producing power after a five-minute wait time.
3. Check the LED on the connector side of the microinverter.

LED color	Indicates
Flashing green	Normal operation. AC grid function is normal, and there is communication with the IQ Gateway.
Flashing orange	The AC grid is normal, but there is no communication with the IQ Gateway.
Flashing red	The AC grid is either not present or not within the specification.
Solid red	There is an active “DC Resistance Low, Power Off Condition” To reset, refer to DC Resistance Low – Power off condition .

4.11 Set up and activate monitoring

To install the IQ Gateway and set up system monitoring and grid management functions, see the [IQ Gateway quick install guide](#). This guide leads you through the following:

- Connecting the gateway
- Detecting devices
- Connecting to the Enphase Installer Portal
- Registering the system
- Building the virtual array



NOTE: When the electricity network operator requires a grid profile other than the profile set on the microinverter, you must select an appropriate grid profile for your installation. You can set the grid profile through the Enphase Installer Portal, during system registration, or through the Enphase Installer App at any time. You must have an IQ Gateway to set or change the grid profile to be compliant with certain jurisdictions.

5. Troubleshooting

Follow all the safety measures described in this manual. Qualified personnel can use the following troubleshooting steps if the PV system does not operate correctly.



WARNING: Risk of electric shock. Do not attempt to repair the Enphase microinverter; it contains no user-serviceable parts. If it fails, contact Enphase Support to obtain an RMA (return merchandise authorization) number and start the replacement process.

5.1 Status LED indications and error reporting

5.1.1 LED operation

LED color	Indicates
Flashing green	Normal operation. AC grid function is normal, and there is communication with the IQ Gateway.
Flashing orange	The AC grid is normal, but there is no communication with the IQ Gateway.
Flashing red	The AC grid is either not present or not within the specification.
Solid red	There is an active “DC Resistance Low – Power Off” condition. If the problem persists, measure resistance between PV+ to EARTH and then PV- to EARTH on the PV module and then inverter. Anything less than ~7 kΩ will trigger the “DC Resistance Low – Power Off” condition. Usually, the value is in MΩ on the inverter or PV module. Swap out faulty PV module or microinverter.

The status LED on each microinverter lights green about six seconds after DC power is applied. It remains lit solid for two minutes, followed by six green blinks. After that, red blinks indicate that no grid is present if the system is not yet energized.

Any short red blinks after DC power is first applied to the microinverter indicate a failure during microinverter start-up.

5.1.2 DC Resistance Low – Power off condition

For all IQ Series models, a solid red status LED when DC power has been cycled indicates the microinverter has detected a DC Resistance Low–Power Off event. The LED will remain red, and the fault will continue to be reported by the gateway until the error has been cleared.

An insulation resistance (IR) sensor in the microinverter measures the resistance between the positive and negative PV inputs to the ground. If either resistance drops below a threshold, the microinverter stops power production and raises this condition. This may indicate defective module insulation, defective wiring or connectors, moisture ingress, or a similar problem. Although the cause may be temporary, this microinverter condition persists until the sensor is manually reset.

An IQ Gateway is required to clear this condition. The condition clears on operator command unless its cause is still present.

If a microinverter registers a “DC Resistance Low - Power Off” condition, you can attempt to clear this condition. If the condition does not clear after you perform the following procedure, contact [Enphase Support](#).

There are two ways to send a clear message to the microinverter. Note that the condition will not clear after the sensor reset if the cause of the failure is still present. If the condition persists, contact your installer.

Clearing the error using the Enphase Installer Portal

1. Log in to the Enphase Installer Portal and access the system.
2. Click the **Events** tab. The next screen shows the current **DC Resistance Low - Power Off** condition of the system.
3. Click **DC Resistance Low - Power Off**.
4. Where “n” is the number of affected devices, click **n devices (show details)**.
5. Click the serial number of the affected microinverter.
6. Click **Reset DC Resistance Low - Power Off Sensor**.
7. The system displays that a **DC Resistance Low-Power Off reset task was issued on [date and time] for this microinverter and is still pending**.

5.1.3 Other faults

All other faults are reported to the gateway.

5.2 Troubleshoot an inoperable microinverter

To troubleshoot an inoperable microinverter, follow the steps in the order shown.



WARNING: Risk of electric shock. Always de-energize the AC branch circuit before servicing. Never disconnect the DC connectors under load.



WARNING: The Enphase microinverters are powered by DC power from the PV modules. Ensure you disconnect the DC connections, reconnect the DC power, and then watch for the solid green about six seconds after connection to DC power.

1. Ensure AC breakers and disconnects are closed.
2. Check the connection to the utility grid and verify that the utility voltage is within allowable ranges.
3. Verify that AC line voltages at all solar power circuit breakers at the load center and subpanels are within the ranges shown in the following table.

240 VAC, single-phase

L1 to L2	211 to 264 VAC
----------	----------------

220 VAC, single-phase

L1 to L2	198 to 242 VAC
----------	----------------

220 VAC, three-phase

L1 to L2	198 to 242 VAC
----------	----------------

4. Using an IQ Disconnect Tool, disconnect the AC cable from the IQ Cable for the microinverter in question.
5. Verify that utility power is present at the microinverter by measuring line to line and line to ground at the IQ Cable connector.
6. Visually check that the AC branch circuit connections (IQ Cable and AC connections) are properly seated. Reset if necessary. Check also for damage, such as rodent damage.
7. Ensure that any upstream AC disconnects, as well as the dedicated circuit breakers for each AC branch circuit, are functioning properly and are closed.
8. Disconnect and re-connect the DC PV module connectors. The status LED of each microinverter will light solid green a few seconds after connection to DC power and then blink green six times

to indicate normal start-up operation about two minutes after connecting to DC power. The LED subsequently resumes normal operation if the grid is present. See the table on the previous page outlining LED indicators for normal operation.

9. Connect a clamp meter to one of the conductors of the DC cables from the PV module to measure the microinverter current. This will be under 1 A if the AC is disconnected.
10. Verify the PV module DC voltage is within the allowable range shown in the [Specifications](#) in this manual. Refer to the Enphase compatibility calculator at <https://enphase.com/en-ph/installers/microinverters/calculator> to verify PV module electrical compatibility with the microinverter.
11. Swap DC leads with a known good, adjacent PV module. If, after checking the Enphase Installer Portal periodically (this may take up to 30 minutes), the problem moves to the adjacent module, this indicates that the PV module is not functioning correctly. If it stays in place, the problem is with the original microinverter.
Contact [Enphase Support](#) for help in reading the microinverter data and for help in obtaining a replacement microinverter, if needed.
12. Check the DC connections between the microinverter and the PV module. The connection may need to be tightened or reseated. If the connection is worn or damaged, it may need replacement.
13. Verify with your utility that the line frequency is within range.
14. If the problem persists, contact [Enphase Support](#).

5.3 Disconnect a microinverter

If problems remain after following the troubleshooting steps listed previously, contact [Enphase Support](#). If Enphase authorizes a replacement, follow these steps. To ensure the microinverter is not disconnected from the PV modules under load, follow the disconnection steps in the order shown:

1. De-energize the AC branch circuit breaker.
2. AC connectors are tool-removable only. To disconnect the microinverter from the IQ Cable, insert the disconnect tool and remove the connector.
3. Cover the PV module with an opaque cover.
4. Using a clamp-on meter, verify there is no current flowing in the DC wires between the PV module and the microinverter. If the current is still flowing, check that you have completed steps A and B above.



NOTE: Take care when measuring DC current, as most clamp-on meters must be zeroed first and tend to drift with time.

5. Disconnect the PV module DC wire connectors from the microinverter using the IQ Disconnect Tool.
6. If present, loosen and/or remove any bonding hardware.
7. Remove the microinverter from the PV racking.



WARNING: Risk of electric shock. Risk of fire. Do not leave any connectors on the PV system disconnected for an extended period. If you do not plan to replace the microinverter immediately, you must cover any unused connector with an IQ Sealing Cap.

5.4 Install a replacement microinverter

1. When the replacement microinverter is available, verify that the AC branch circuit breaker is de-energized.
2. Mount the microinverter horizontally, bracket side up, or vertically.
 - Always place the microinverter under the PV module, protected from direct exposure to rain, sun, and other harmful weather events. Allow a minimum of 1.9 cm (3/4") between the roof and the microinverter. Also, allow 1.3 cm (1/2") between the back of the PV module and the top of the microinverter.
 - For vertical mount, also maintain >30 cm (12") clearance from the edges of the PV module to protect the microinverter from direct exposure to rain, UV, and other harmful weather events.



WARNING: Risk of equipment damage. Mount the microinverter under the PV module.

- Install the microinverter under the PV module to avoid direct exposure to rain, UV, and other harmful weather events.
 - Always install the microinverter bracket side up.
 - Do not mount the microinverter upside down.
 - Do not expose the AC or DC connectors (on the IQ Cable connection, PV module, or microinverter) to rain or condensation before the connectors are mated.
3. Torque the mounting fasteners to the values shown. Do not over-torque.
 - 6 mm (1/4") mounting hardware: 5 N m (45 to 50 in-lb)
 - 8 mm (5/16") mounting hardware: 9 N m (80 to 85 in-lb)
 - When using UL 2703 mounting hardware, use the manufacturer's recommended torque value.
 4. If you are using bonding hardware, the old bonding hardware should be discarded, and new bonding hardware must be used when installing the replacement microinverter.
 5. Connect the microinverter to the IQ Cable connector. Listen for a click as connectors engage.
 6. Connect the DC leads of each PV module to the DC input connector of the microinverter.
 7. Re-mount the PV module above the microinverter.
 8. Energize the AC branch circuit breaker and verify the operation of the replacement microinverter by checking the Status LED on the connector side of the microinverter.
 9. Use the Enphase Installer App to delete the old microinverter serial number from the IQ Gateway database. In the Enphase Installer App, once connected to the IQ Gateway:
 - a. Tap **Devices & Array > IQ Microinverters & Array > IQ Microinverter Serial Number**.
 - b. Tap **RETIRE** to retire the old microinverter serial number from the IQ Gateway database.
 - c. Add the new microinverter serial number to the gateway database by scanning the barcode using the Enphase Installer App and your device camera.
 - d. Tap **Devices & Array > IQ Microinverters & Array > ADD DEVICES**. Scan the IQ8P Microinverter's barcode and assign it to the array.

OR

 - e. Go to **Service > Request return and install replacement > Install Replacement**. Enter the original device serial number and replacement device serial number and submit.
 10. Start the provisioning process for the newly added microinverter using the Enphase Installer App and by connecting the Enphase Installer App to IQ Gateway in AP mode. You can then "Start Provisioning Devices" through the Enphase Installer App.
 11. Ship the old microinverter to Enphase using the supplied return shipping label.

6. Replacement parts and cabling

6.1 Enphase IQ Cable planning and ordering

The Enphase IQ Cable is a continuous length of 12 AWG, double insulated, outdoor-rated cable with integrated connectors for microinverters. These connectors are preinstalled along the IQ Cable at intervals to accommodate varying PV module widths. The microinverters plug directly into the cable connectors.

The cabling is compatible with a variety of PV racking systems. For a list of approved PV racking systems, refer to the PV racking compatibility document on the Enphase website at <https://enphase.com/en-ph/installers/resources/documentation>.

6.2 Connector spacing options

IQ Cable is available in three connector spacing options. The gap between connectors on the cable can be 1.3 meters, 2.0 meters, or 2.3 meters. The 1.3-meter spacing is best suited for connecting PV modules installed in portrait orientation, while the 2.0-meter and 2.3-meter spacing allows you to install in landscape orientation for PV modules with 54-cell/108-half-cell, 60-cell/120-half-cell, 66-cell/132-half-cell, 72-cell/144-half-cell configurations.

6.3 IQ Cable options

Cable model	Connector spacing	Connector count per box
Q-12-10-240	1.3 m (50")	240
Q-12-12-240	1.5 m (60")	240
Q-12-17-240	2.0 m (78")	240
Q-12-18-240	2.1 m (83")	240
Q-12-20-200	2.3 m (90")	200
Q-12-22-200	2.5 m (98")	200
Q-12-25-200	2.8 m (110")	200

The cabling system is flexible enough to adapt to almost any solar design. To determine the cable type you need, apply the following considerations:

- When mixing PV modules in both portrait and landscape orientation, you may need to transition between cable types. See the preceding table for available cable types.
- To transition between cable types, install an IQ Field Wireable Connector pair.
- In situations where portrait modules are widely spaced, you may need to use landscape-spaced cables for the portrait-oriented PV modules and create loops of excess cable, if needed.



WARNING: Do not form loops smaller than 12 cm (4.75") in diameter.

6.4 Enphase IQ Cable accessories

The IQ Cable is available with several accessory options for ease of installation, including:

- IQ Field Wireable Connector (male): (Q-CONN-10M) Make connections from any field wireable female connector.
- IQ Field Wireable Connector (female): (Q-CONN-10F) Make connections from any IQ Cable open connector or field wireable male connector.
- IQ Cable Clips: (Q-CLIP-100) Used to fasten cabling to the racking or to secure looped cabling.
- IQ Disconnect Tool: (Q-DISC-10) Disconnect tool for IQ Cable connectors, DC connectors, and AC module mount.
- IQ Sealing Caps (female): (Q-SEAL-10) One needed to cover each unused connector on the cabling.
- IQ Terminator: (Q-TERM-10) Terminator cap for cut cable ends.

7. Technical data

7.1 Technical considerations



WARNING: Risk of equipment damage. You must match the DC operating voltage range of the PV module with the allowable input voltage range of the microinverter.



WARNING: Risk of equipment damage. The maximum open circuit voltage of the PV module must not exceed the specified maximum input voltage of the Enphase microinverter.

Be sure to apply the following when installing the Enphase IQ8 Series Microinverter system:

- PV modules must have conductors labeled "PV Wire" or "PV Cable" to comply with NEC for ungrounded PV power systems.
- Verify that the voltage and current specifications of the PV module match those of the microinverter.
- The maximum short circuit current rating of the PV module must be equal to or less than the maximum input DC short circuit current rating of the microinverter.

The output voltage and current of the PV module depend on the quantity, size, and temperature of the PV cells, as well as the insolation of each cell. The highest PV module output voltage occurs when the temperature of the cells is the lowest, and the PV module is at an open circuit (not operating).

7.2 Bifacial modules

Enphase microinverters are compatible with bifacial PV modules. Bifacial solar modules produce power from both sides of a bifacial module, increasing total energy generation. The power gained from the rear side (bifacial gain) is highly influenced by various design factors such as albedo, module elevation, pitch, temperature, and shading. The bifacial gain can be anywhere between 0% to 30% of

the nominal rating (front-side power rating) of the module. Since the bifacial gain is highly influenced by various design considerations, pairing the bifacial module with the right microinverter depends on the electrical characteristics of a given module.

8. Specifications

See the specifications in the following tables:

- IQ8P-72-2-US Microinverters
- IQ Cable

8.1 IQ8P-72-2-US Microinverters

Input data (DC)	Parameter	Units	IQ8P-72-2-US
Typical module compatibility	—	—	60-cell/120-half-cell, 66-cell/132-half-cell, 72-cell/144-half-cell, 78-cell/156-half-cell No enforced DC/AC ratio and maximum input power. Modules can be paired if the maximum input voltage is not exceeded and the maximum input current of the inverter at the lowest and highest temperatures is respected. See the compatibility calculator at https://enphase.com/en-ph/installers/microinverters/calculator .
Minimum/Maximum input voltage	U_{dcmin}/U_{dcmax}	V	16/65
Start-up input voltage	$U_{dcstart}$	V	22
Minimum/Maximum MPP voltage	U_{mppmin}/U_{mppmax}	V	36/55
Minimum/Maximum operating voltage	U_{opmin}/U_{opmax}	V	16/65
Maximum input current	I_{dcmax}	A	14
Maximum short-circuit DC input current	I_{scmax}	A	25
Maximum module I_{sc}	I_{scmax}	A	20
Maximum input power ¹	P_{dcmax}	W	640
Output data (AC)	Parameter	Units	IQ8P-72-2-US
Maximum apparent power	$S_{ac, max}$	VA	480

Output data (AC)	Parameter	Units	IQ8P-72-2-US
Rated power	$P_{ac,r}$	W	475
Nominal grid voltage	U_{acnom}	V	240/220
Minimum/Maximum grid voltage	U_{acmin}/U_{acmax}	V	184/276
Maximum output current	I_{acmax}	A	2.00/2.18
Nominal frequency	f_{nom}	Hz	60
Minimum/Maximum frequency	f_{min}/f_{max}	Hz	47/68
Maximum units per single/multi-phase 20 A circuit	$A/I_{ac,max}$	—	8 (240 V L+L)/7 (220 V L+L)
Protective class (all ports)	—	—	II
Total harmonic distortion	—	%	<5
Power factor setting	—	—	1.0
Power factor range	cos phi	—	0.85 leading ... 0.85 lagging
Inverter maximum efficiency	η_{max}	%	97.57
CEC weighted efficiency	η_{EU}	%	97
Inverter topology	—	—	Isolated (HF transformer)
Nighttime power loss	—	mW	100

Mechanical data	IQ8P-72-2-US
Ambient air temperature range	-40°C to 65°C (-40°F to 149°F)
Relative humidity range	4% to 100% (condensing)
Overvoltage class AC port	III
Number of input DC connectors (pairs) per single MPP-tracker	1
AC connector type	IQ Cabling (refer to separate datasheet for cable and accessories)
DC connector type	Supplied with Stäubli MC4 adapter
Dimensions (H × W × D)	263.5 mm (10.4") × 196.3 mm (7.7") × 36.1 mm (1.4") (without mounting brackets)
Weight (with mounting plate)	1.6 kg (3.5 lb)
IP rating	NEMA Type 6/outdoor - IP67
Maximum altitude	<2,600 m (8,530 feet)
Calorific value	59.25 MJ/unit

Mechanical data	IQ8P-72-2-US
Certifications	<p>CA Rule 21 (UL 1741-SB), UL 62109-1, UL 1741/IEEE1547, FCC Part 15 Class B, ICES-0003 Class B, CAN/CSA-C22.2 NO. 107.1-01</p> <p>This product is UL Listed as PV rapid shutdown equipment and conforms with NEC 2014, NEC 2017, NEC 2020, and NEC 2023 section 690.12 and C22.1-2018 rule 64-218 rapid shutdown of PV systems, for AC and DC conductors, when installed according to manufacturer's instructions.</p>

¹Pairing PV modules with wattage above the limit may result in additional clipping losses. See the compatibility calculator for suitability at <https://enphase.com/en-ph/installers/microinverters/calculator>.

8.2 IQ Cable specifications

Specification	Value
Voltage rating	600 V
Voltage withstand test (kV/1 min)	AC 3.0
Max DC conductor resistance (20°C) (Ω/km)	5.433
Insulation resistance (20°C)	≥20 M (Ω/Km)
System temperature range (ambient)	-40°C to 65°C (-40°F to 149°F)
Cable temperature rating	90°C Dry/90°C Wet
Cable rating	DG
Certification	UL 3003, TC-ER equivalent
Flame test rating	FT4
Cable conductor insulator rating	THHN/THWN-2
Environmental protection rating	IEC 60529 IP67/NEMA 6
UV resistance	720 h
Compliance	RoHS, OIL RES I, CE, UV resistant, combined UL for Canada and the United States
Conductor size	12 AWG
Maximum loop size	12 cm (4.75 ")
Flat cable dimensions	6 mm × 9.5 mm (0.2" × 0.37")
Sealing cap dimensions	38.6 mm × 20 mm (1.5" × 0.7")
Cable connector dimensions	20 mm × 1.1 mm × 6.5 mm (0.7" × 0.04" × 0.25")

8.3 Enphase connector ratings

Enphase connectors on the cable assemblies in the following table have a maximum current of 20 A, a maximum OCPD of 20 A, and a maximum ambient temperature of -40° to 79°C (-40° to 174.2°F) and are rated for disconnection under load.

Part number	Model	Maximum voltage
840-00387	Q-12-10-240	277 VAC
840-01934	Q-12-12-240	277 VAC
840-00388	Q-12-17-240	277 VAC
840-01935	Q-12-18-240	277 VAC
840-00389	Q-12-20-200	277 VAC
840-01937	Q-12-22-200	277 VAC
840-01936	Q-12-25-200	277 VAC

9. Enphase installation map

To Sheet / A la hoja de: 

Panel Group/Grupo de los paneles: Azimuth/Azimut: Tilt/Inclinación: Sheet/Hoja ____ of/de ____		Customer/Cliente:				Installer/Instalador:			N S E W N S E O
1	2	3	4	5	6	7			
A									
B									
C									
D									
E									
F									
G									
H									
J									
K									
L									
M									

To Sheet / A la hoja de: 

Scan completed map and upload it to Enphase. Click "Add a New System" at <https://enlighten.enphaseenergy.com>. Use this map to build the virtual array in Enlighten's Array Builder. /

Escanee el mapa completo y cárguelo en Enphase. Haga clic en "Añadir nuevo sistema" en <https://enlighten.enphaseenergy.com>. Utilice este mapa para crear el conjunto de paneles virtual en el Creador de conjuntos de paneles de Enlighten.

Envo Serial Number Label /
Número de serie de Envoy



To Sheet / A la hoja de: 

10. Sample single-phase wiring diagram

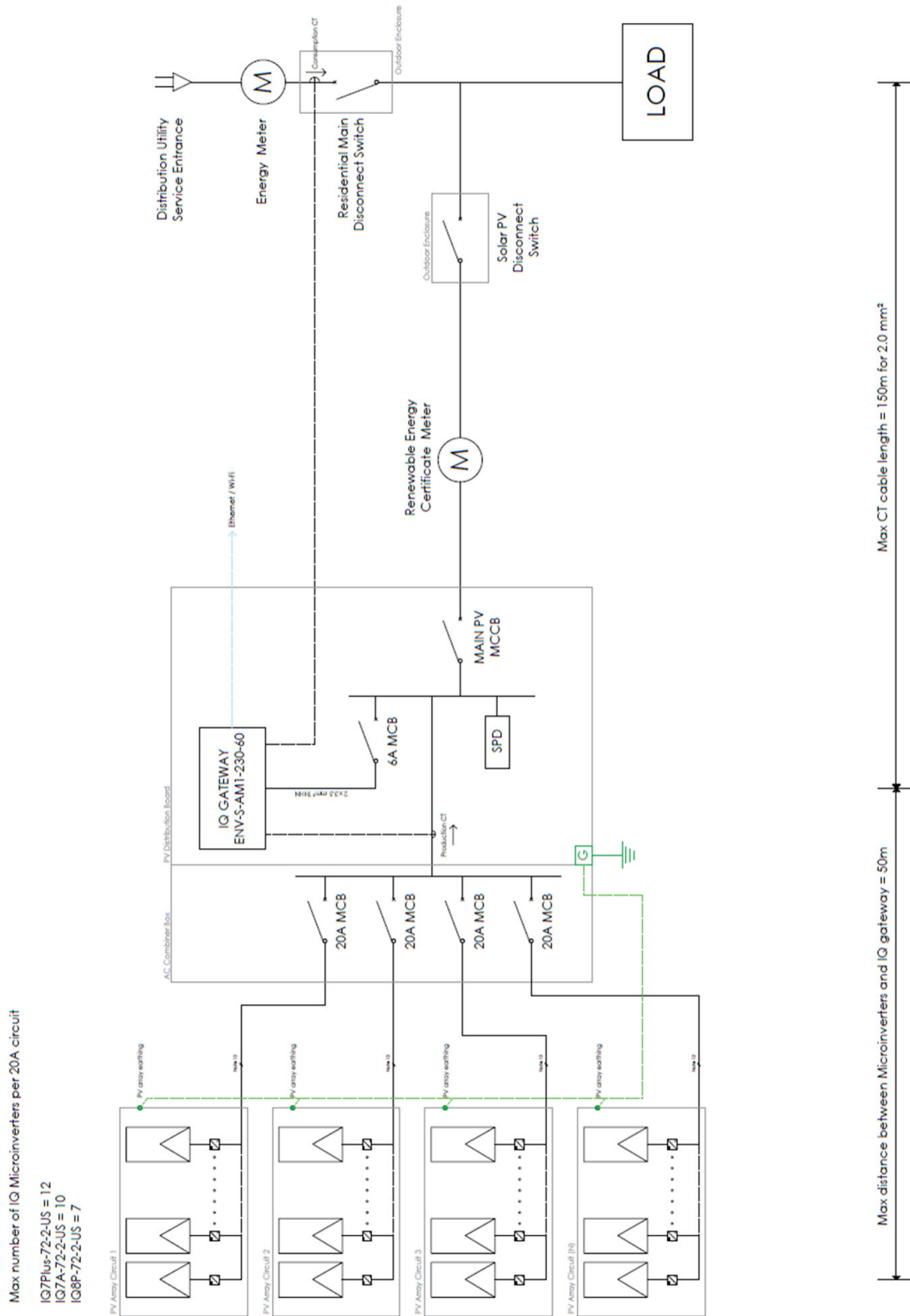

11. Sample three-phase wiring diagram

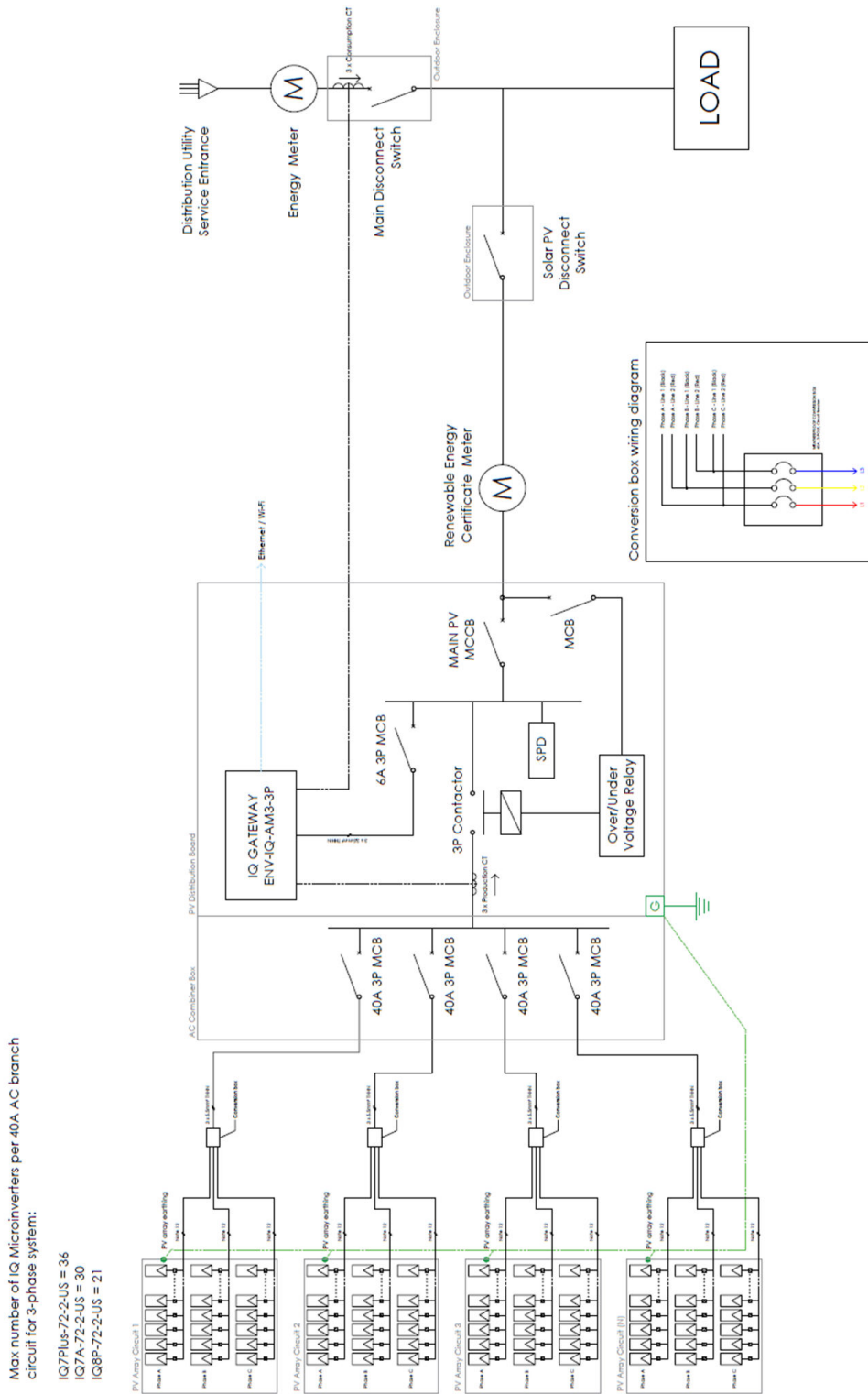

12. Revision history

Revision	Date	Description
IOM-00002-2.0	December 2024	Updated information on backward compatibility with IQ7 Series Microinverters.
IOM-00002-1.0	January 2024	Initial release.