

Installing Enphase 400A Production CTs

Use this instruction with the *Enphase IQ8D Commercial Envoy Quick Install Guide* to install Enphase production monitoring Current Transformers (CTs). The Enphase IQ8D Commercial Envoy gateway uses a set of three 400A solid core CTs for monitoring solar production current. This CT performs metering with accuracy class of 0.2%. Rated at Pollution Degree 3, you can use the CT inside electrical equipment in residential or in harsh, industrial conditions. Read and follow all warnings and instructions in this instruction and in the Quick Install Guide included with your Envoy and available at: enphase.com/support.

SAFETY

SAFETY AND ADVISORY SYMBOLS

	DANGER: This indicates a hazardous situation, which if not avoided, will result in death or serious injury.
	NOTE: This indicates information particularly important for optimal system operation. Follow instructions carefully.

SAFETY INSTRUCTIONS

	DANGER: To reduce the risk of electric shock, always open or disconnect circuit from power-distribution system (or service) of building before installing or servicing current transformers.
	DANGER: Risk of electrocution! Do not install CTs when current flowing in the sensed circuit. Always install CT wires in the terminal blocks before energizing the sensed circuit.
	DANGER: If equipment is used in a manner not specified by Enphase Energy, the protection provided by the equipment may be impaired.
	DANGER: Risk of electric shock. Be aware that installation of this equipment includes risk of electric shock. If you wire the IQ Envoy at the subpanel, always de-energize the subpanel before beginning.
	DANGER: Risk of electric shock. Risk of fire. Only qualified personnel should troubleshoot, install, or replace the CTs.
	NOTE: Because of variance in switchboard design and main power feed, there may not always be enough space to install CTs.
	NOTE: Do not install the CTs in a switchboard where they exceed 75% of the wiring space of any cross-sectional area within the equipment.
	NOTE: Perform all electrical installations in accordance with all national and local electrical codes.
	NOTE: Restrict installation of current transformers in an area where they would block ventilation openings, or in area of breaker arc venting.
	NOTE: Not suitable for Class 2 wiring methods and not intended for connection to Class 2 equipment.
	NOTE: Secure current transformer and route conductors so that they do not directly contact live terminals or bus.
	NOTE: When wiring the IQ Envoy for production and consumption metering, be sure to install the current transformers (CTs) exactly as described for your application.
	NOTE: When installing CTs, it is important to match CT and sense voltage phases. Be sure to consistently identify the two AC lines at three points: the main load center feed, the Envoy, and the solar production circuit breaker. Wire colors (typically black and red) may not always consistently identify L1 and L2. If in doubt, use a multimeter to check.
	NOTE: Only run active conductors through the CT. The CT can monitor multiple active conductors. You may run more than one wire through the CT if all wires are on the same phase and they fit the opening in the CT.

SPECIFICATIONS

SPECIFICATION	CT-400-SOLID
CT type	Solid core
CT accuracy (error rate)	<0.5%
Max primary supported current	400A
Turns ratio	2000
Pollution degree	3
Dimensions	76mm diameter * 18.1mm thickness
Aperture	43mm diameter
Primary voltage (range)	250VAC max
Frequency	60Hz (45 - 66Hz)
Operating temperature	-40 to 85 degree C
Humidity	95%
Pollution degree	3
Compliance	ROHS(latest version)

INSTALLATION

For more information, refer to the *IQ8D Commercial Envoy Quick Install Guide* available at: enphase.com/support.



Preparation

- A) If not already done, turn off power to the PV system.

Remove any pre-installed production CTs

- A) Remove the line 1, line 2 and line 3 conductors of the solar production circuits on which the CTs are connected.
- B) Remove the existing CTs.

Install the production CTs

- A) Before running the CT wires through the conduit, use colored tape to mark one of the CTs and the free end of its wires.
- B) For each CT, locate the arrow on the CT label.
- C) Refer to the diagram on the reverse of this document for wiring.
- D) Install the production CTs on active phases as required:
 - Locate the arrow on the CT label.
 - **To monitor production on Line 1:**
 - Connect the white wire to the white "P1" terminal and the blue wire to the blue "P1" terminal.
 - Pass Line 1 of the solar production circuit through the CT with the arrow pointing toward the load (away from the solar array).
 - **To monitor production on Line 2:**
 - Connect the white wire to the white "P2" terminal and the blue wire to the blue "P2" terminal.
 - Pass Line 2 of the solar production circuit through the CT with the arrow pointing toward the load (away from the solar array).
 - **To monitor production on Line 3:**
 - Connect the white wire to the white "P3" terminal and the blue wire to the blue "P3" terminal.
 - Pass Line 3 of the solar production circuit through the CT with the arrow pointing toward the load (away from the solar array).
 - **Tighten all connections to 5 in-lbs (0.6 N m).**
- E) Close and secure the terminal block door of the Envoy.
- F) Turn on the PV system.

IQ Commercial Envoy Terminal Block

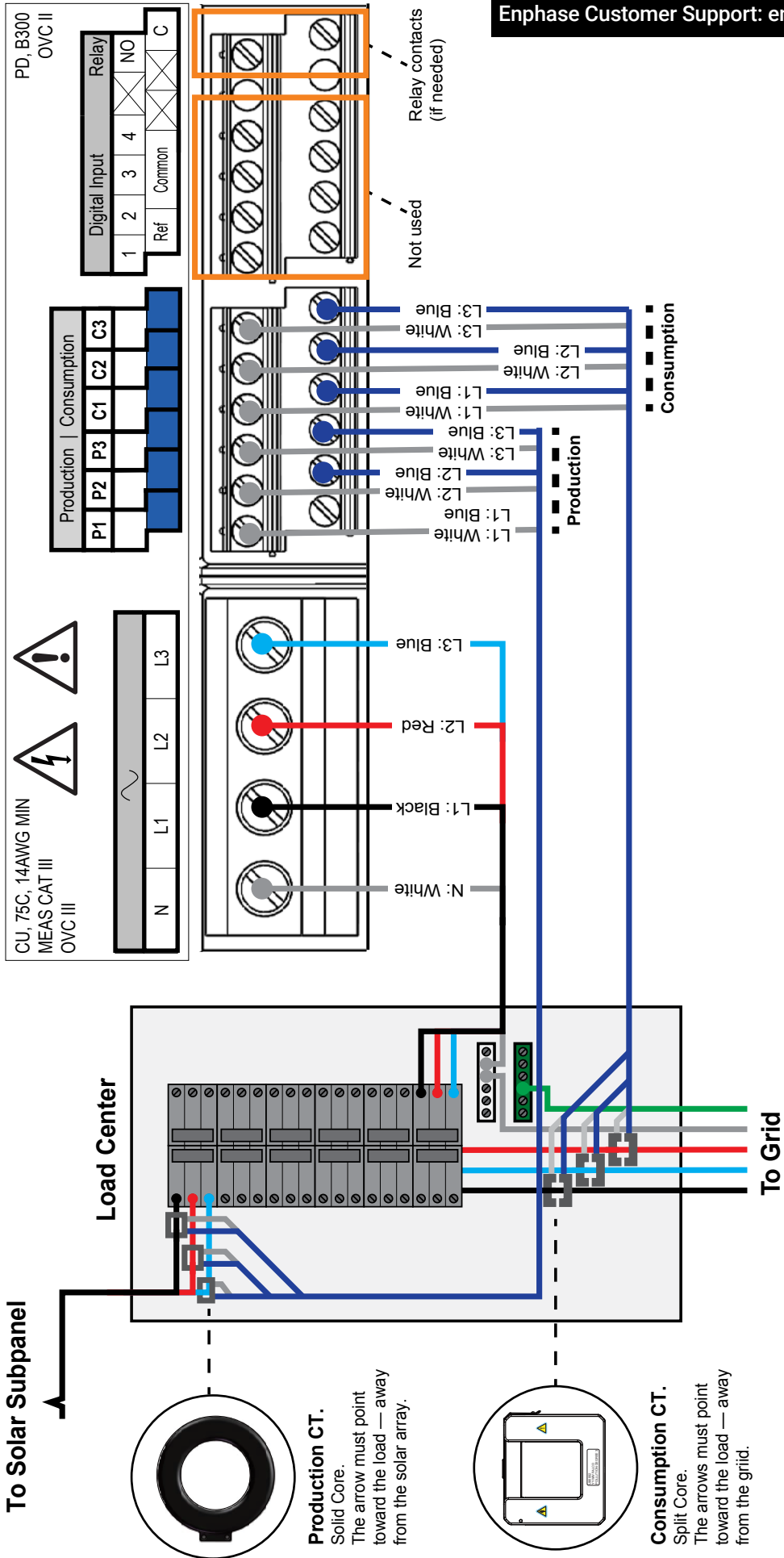

© 2021 Enphase Energy. All rights reserved. Enphase, the Enphase logo, Enphase Enlighten, Enphase IQ8D Commercial Envoy, and other trademarks or service names are the trademarks of Enphase Energy, Inc. Data subject to change. 2021-04-01



140-00183-01